

### Additional Data/Spec Sheet

LIWA brand | Filler Cap Antisplash | Screw Fixing Flange 6 Mounting Holes | Polyamide Housing & Basket  
3Micron nom. Cellulose Filter | Hydraulic Oil Tank Accessory

## FB2 SERIES

### TECHNICAL FEATURES:

- Cover: Polyamide PA
- Inner Air Filter: 3 Micron nom. Cellulose
- Flange: Polyamide PA DIN 24557/2
- Basket: Polyamide PA
- Anti-splash device
- Temperature: -25°C to +100°C

**Screw Fixing Flange 6Hole Mounting | Polyamide PA | 3mic nom Cellulose | Anti-Splash Device**

Fluidco Part nr	LIWA Part nr	
FB-FB2-TRUCK	FB250D2C10	Dimensions Below

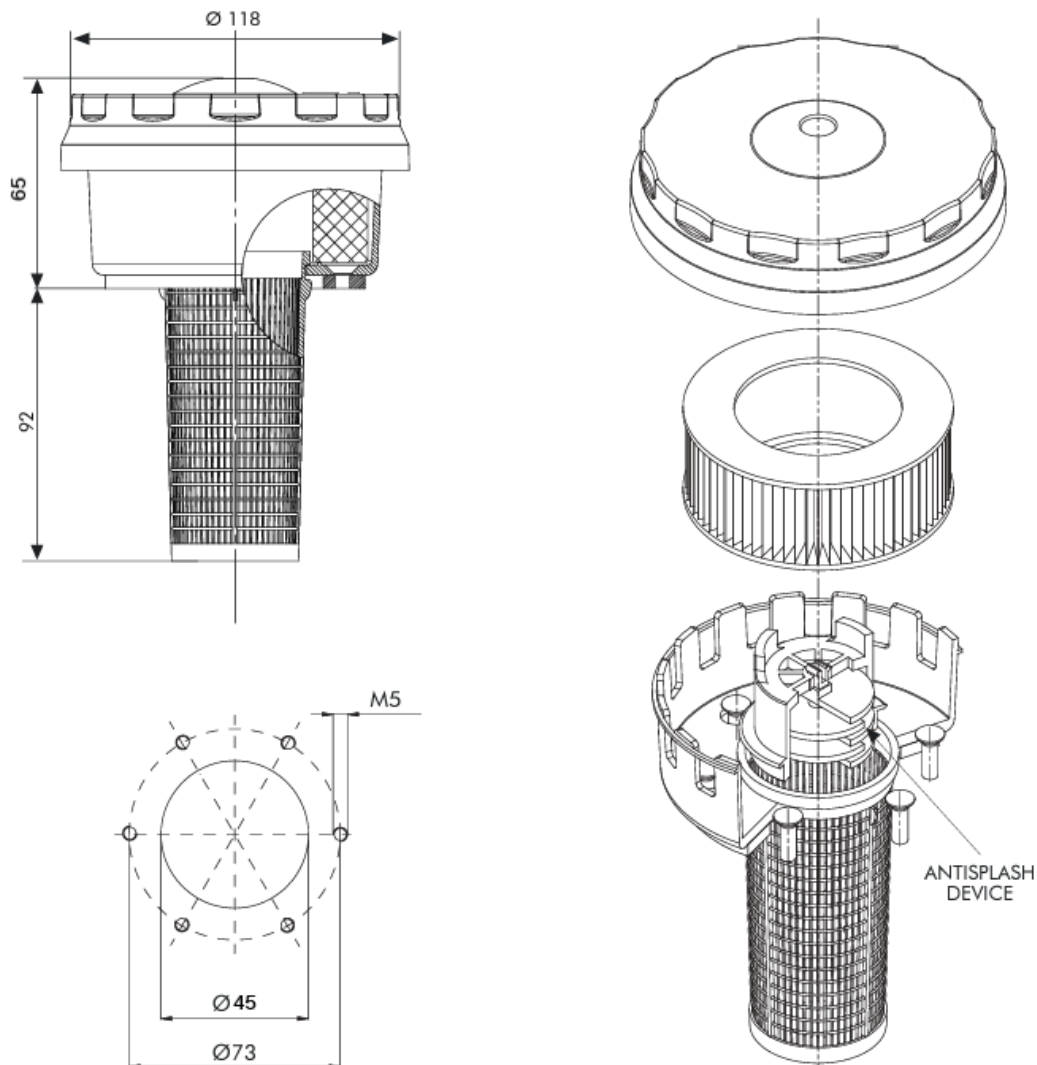



[www.fluidco.co.za](http://www.fluidco.co.za) *Make it Happen!*

The Filler Breather with Anti-Splash device allows the Oil Tank to be subject to strong shocks or oscillations, the device prevents oil splashes from escaping and wetting the filter element.

The Air Breather filters are an integral part of the filtration within the hydraulic system, as they retain the environment contamination that could enter into the reservoir with the air sucked due to the oil level fluctuations during the system operation.