

Additional Data/Spec Sheet

MP Filtri TAP 90 Series | Filler Breather & Polyamide Air Filter | Max 550Lpm | Screwed Flange DIN 24557-2
Polyurethane 10µm Filtration | NBR Seal | No Pressurization valve | No Dipstick or padlock | 120mm Basket

TAP 90 GENERAL INFORMATION



TECHNICAL FEATURES:

- Flanged connection with bayonet, for a max Flow rate of 550Lpm
- Fine cellulose filtration, to get a good cleanliness level into the reservoir
- Filling basket, to hold the coarse contamination contained into the fluid and to diffuse the fluid flow into the tank
- Polyamide Flange, Cover, Ringnut
- Basket and Screws are Galvanized Steel
- Polyurethane Filter Element – 10 Micron nom.
- Temperature: -25°C to +100°C

Part Numbers		Dimensions mm
Fluidco Part nr	MP Filtri Part Nr	H1
FB-FB2-P	TAP90F10A001P01	120

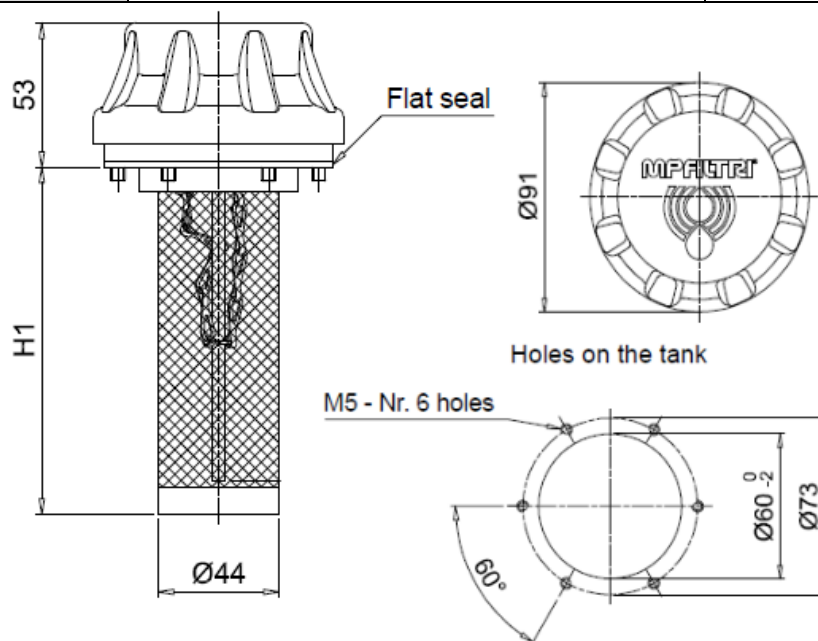

Filler plug and polyamide air filters Flow rates up to 550 l/min

TAP90 is a range of plastic air breathers and filler caps for protection of the tank against the solid contamination contained into the air and filling of the fluid into the systems during the commissioning and maintenance procedures.

They are directly fitted on the tank.

Common applications:

- Hydraulic systems
- Mobile machines
- Industrial equipment