

### Additional Data/Spec Sheet

82 Series – Low Pressure – Push-Lok Barb Fitting – NPTF Male

Straight - Rigid – Self-grip Hose Fitting – SAE J476A/J516 – Brass Body

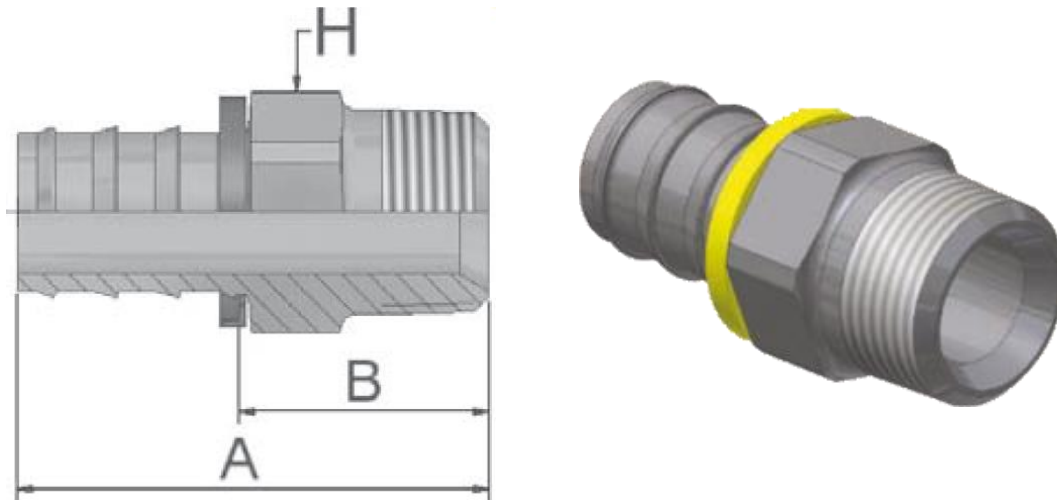

**To be used with Push-Lok Hose or Equivalent Hose**

Approved fitting series for hose types:



Fluidco and Parker 82 Series Part Number 	Hose I.D.				Thread NPTF	A mm	B mm	H Inch
	DN	Inch	Size	mm				
PL-NPTM-0204B   30182-2-4B	6	1/4	-4	6,3	1/8x27	35	16	7/16
PL-NPTM-0404B   30182-4-4B	6	1/4	-4	6,3	1/4x18	40	21	9/16
PL-NPTM-0406B   30182-4-6B	10	3/8	-6	9,5	1/4x18	45	22	9/16
PL-NPTM-0606B   30182-6-6B	10	3/8	-6	9,5	3/8x18	45	22	11/16
PL-NPTM-0608B   30182-6-8B	12	1/2	-8	12,7	3/8x18	49	22	11/16
PL-NPTM-0806B   30182-8-6B	10	3/8	-6	9,5	1/2x14	52	29	22
PL-NPTM-0808B   30182-8-8B	12	1/2	-8	12,7	1/2x14	55	29	7/8
PL-NPTM-0812B   30182-8-12B	20	3/4	-12	19,1	1/2x14	66	29	7/8
PL-NPTM-1212B   30182-12-12B	20	3/4	-12	19,1	3/4x14	66	29	1-1/16

### Industry Applications:

Machine Tools, Paper Industry, Injection Moulding Machines, Chemical Industry, Transfer Lines, Automotive, Blow Forming Machines, Robots, Welding Installations, Power Electronics.

### Main Applications:

Cooling and cutting fluid circuits, Water circuits for tool cooling and temperature control, Compressed air, Leak oil, Water, emulsions and alkalis, Vacuum, Welding gun cooling, Cooling circuits for thyristor controls

### Benefits:

One fitting for all push-lok hoses, Simple assembly without tools or clamps, Long service life, Low assembly cost

### **Assembly Instructions**



1. Cut the hose right angled with a sharp knife. If necessary it is possible to use a lubricant (water/ soap solution with 5 % soap fluid and 95 % water) for easy assembly.
2. Insert fitting into hose until first barb is in hose. Place end of fitting against a flat object (bench, door, wall) and grip hose approximately 1" from end and push with a steady force until end of hose is covered by yellow plastic collar. Alternatively please use the Parker Assembly Tool No. 611050G.

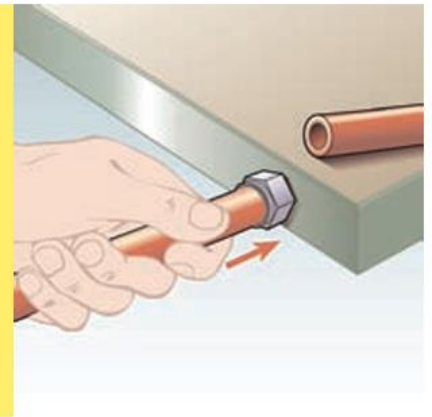

### **Attention!**

During assembly, please keep in mind that Push-Lok fittings will provide an effective grip only when the Push-Lok hose is pushed fully on the insert, where the cropped end of the hose should be fully concealed by the plastic collar.

**For easy assembly of hose 830M, 837BM and 837PU please use only Push-Lok Assembly Oil No. H896137.** Push-Lok Assembly Oil is free from wetting disturbing substances. Don't use oil, lubricant or soap fluids for this hose!

### **Disassembly Instructions**

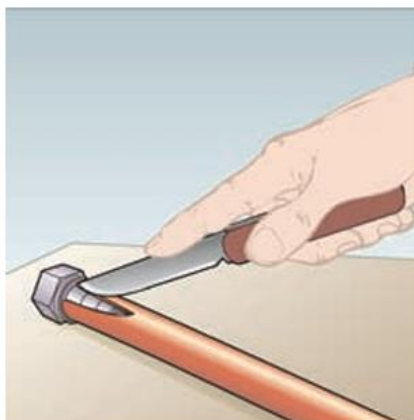

1. Cut lengthwise along a line at approximately a 20 angle from centre line of hose. The cut should be approximately 1" long. Be careful not to nick barbs when cutting the hose.
2. Grip hose and give a sharp down-ward tug to disengage from fitting.

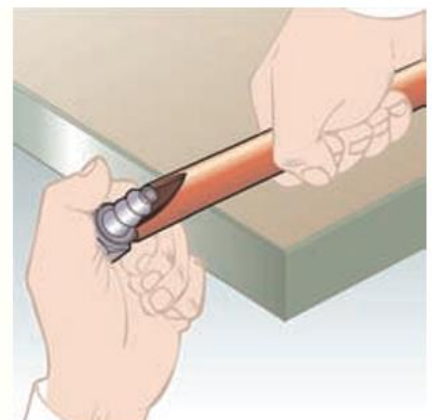

### **Attention!**

Before re-use of the nipple please check nipple for damage. Damaged nipples can cause leakage.