

### Additional Date/Spec Sheet

Group 1 XV-1P Vivoil Aluminium Gear Pumps – Italian Style – Clockwise but Rotation can be changed on request  
CO001 Tapered 1:8 – Ø10 – M7x1 (10-8mm over 15mm) – 2.4mm Key  
Body - BSP 3/8" threaded Ports

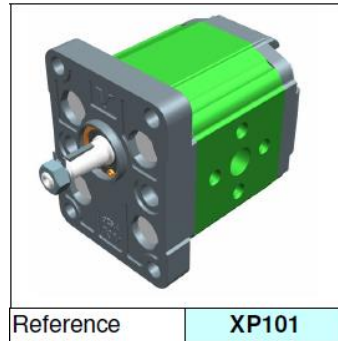

| Dimensions table |        |       |      |       |     |    |      |     |    |      |
|------------------|--------|-------|------|-------|-----|----|------|-----|----|------|
| TYPE             | Weight | A     | B    | C     | D   | E  | F    | D   | E  | F    |
|                  | kg     | mm    | mm   | mm    | IN  |    |      | OUT |    |      |
| <b>XV-1P/9.8</b> | 1,500  | 112,5 | 54,5 | 100,5 | ø12 | 30 | M6x1 | ø12 | 30 | M6x1 |

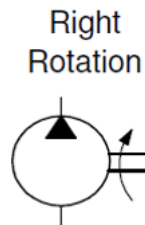
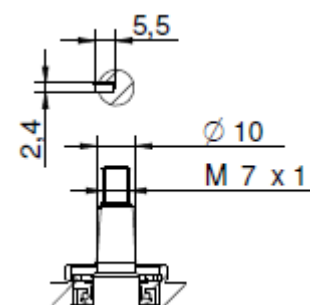
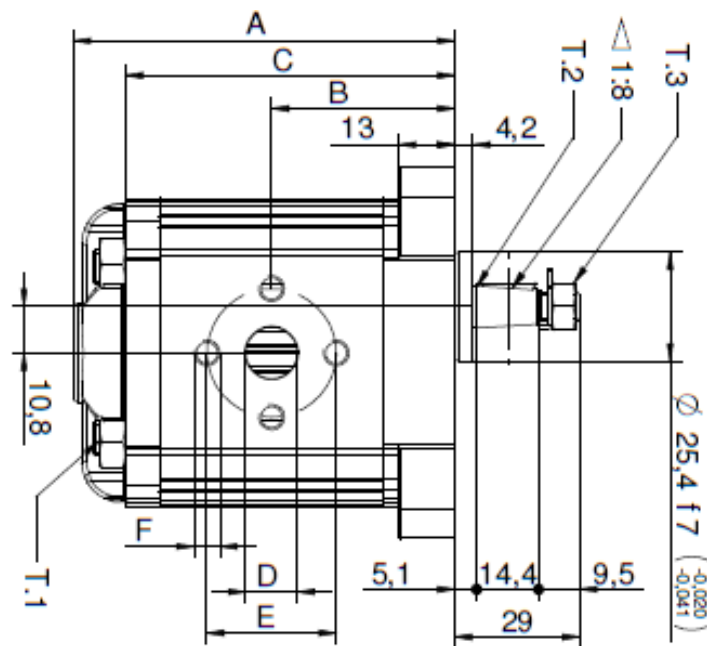
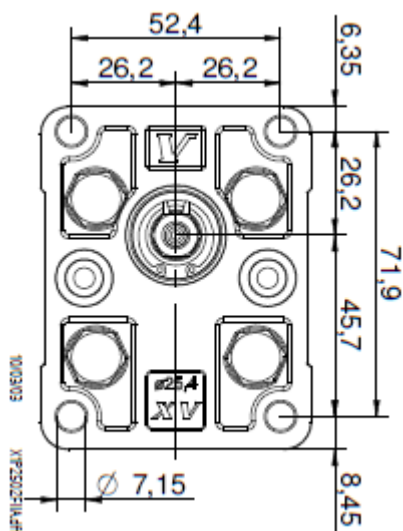
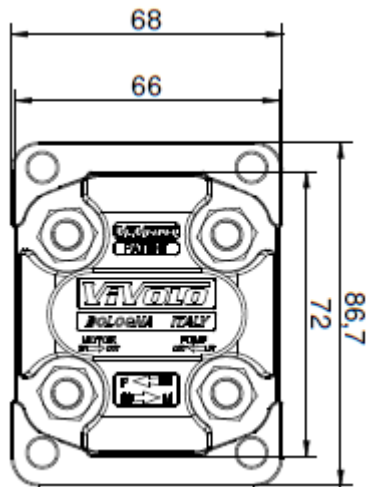

### Summary: Displacements - Pressures - Speeds

| Type      | Displacement              | Max. Pressure | Min speed | Max speed |
|-----------|---------------------------|---------------|-----------|-----------|
| XV-1P/0.9 | 0.91 cm <sup>3</sup> /rev | 280 bar       | 700 rpm   | 6000 rpm  |
| XV-1P/1.2 | 1.17 cm <sup>3</sup> /rev | 290 bar       | 700 rpm   | 6000 rpm  |
| XV-1P/1.7 | 1.56 cm <sup>3</sup> /rev | 290 bar       | 700 rpm   | 6000 rpm  |
| XV-1P/2.2 | 2.08 cm <sup>3</sup> /rev | 290 bar       | 700 rpm   | 6000 rpm  |
| XV-1P/2.6 | 2.60 cm <sup>3</sup> /rev | 300 bar       | 700 rpm   | 6000 rpm  |
| XV-1P/3.2 | 3.12 cm <sup>3</sup> /rev | 300 bar       | 700 rpm   | 6000 rpm  |
| XV-1P/3.8 | 3.64 cm <sup>3</sup> /rev | 300 bar       | 700 rpm   | 6000 rpm  |
| XV-1P/4.3 | 4.16 cm <sup>3</sup> /rev | 300 bar       | 700 rpm   | 6000 rpm  |
| XV-1P/4.9 | 4.94 cm <sup>3</sup> /rev | 300 bar       | 700 rpm   | 6000 rpm  |
| XV-1P/5.9 | 5.85 cm <sup>3</sup> /rev | 300 bar       | 700 rpm   | 5000 rpm  |
| XV-1P/6.5 | 6.50 cm <sup>3</sup> /rev | 300 bar       | 700 rpm   | 5000 rpm  |
| XV-1P/7.8 | 7.54 cm <sup>3</sup> /rev | 260 bar       | 700 rpm   | 5000 rpm  |
| XV-1P/9.8 | 9.88 cm <sup>3</sup> /rev | 230 bar       | 700 rpm   | 4000 rpm  |

| Technical data table |                                      |               |        |                     |                     |  |
|----------------------|--------------------------------------|---------------|--------|---------------------|---------------------|--|
| TYPE                 | Displacement<br>cm <sup>3</sup> /rev | Max. Pressure |        | CODE                |                     |  |
|                      |                                      | P1 bar        | P3 bar | Left rotation       | Right rotation      |  |
| XV-1P/0.9            | 0,91                                 | 240           | 280    | X 1 P 16 01 F I I A | X 1 P 16 02 F I I A |  |
| XV-1P/1.2            | 1,17                                 | 250           | 290    | X 1 P 17 01 F I I A | X 1 P 17 02 F I I A |  |
| XV-1P/1.7            | 1,56                                 | 250           | 290    | X 1 P 18 01 F I I A | X 1 P 18 02 F I I A |  |
| XV-1P/2.2            | 2,08                                 | 250           | 290    | X 1 P 20 01 F I I A | X 1 P 20 02 F I I A |  |
| XV-1P/2.6            | 2,60                                 | 250           | 300    | X 1 P 21 01 F I I A | X 1 P 21 02 F I I A |  |
| XV-1P/3.2            | 3,12                                 | 250           | 300    | X 1 P 23 01 F I I A | X 1 P 23 02 F I I A |  |
| XV-1P/3.8            | 3,64                                 | 250           | 300    | X 1 P 25 01 F I I A | X 1 P 25 02 F I I A |  |
| XV-1P/4.3            | 4,16                                 | 250           | 300    | X 1 P 27 01 F I I A | X 1 P 27 02 F I I A |  |
| XV-1P/4.9            | 4,94                                 | 250           | 300    | X 1 P 29 01 F I I A | X 1 P 29 02 F I I A |  |
| XV-1P/5.9            | 5,85                                 | 250           | 300    | X 1 P 31 01 F I I A | X 1 P 31 02 F I I A |  |
| XV-1P/6.5            | 6,50                                 | 250           | 300    | X 1 P 32 01 F I I A | X 1 P 32 02 F I I A |  |
| XV-1P/7.8            | 7,54                                 | 220           | 260    | X 1 P 34 01 F I I A | X 1 P 34 02 F I I A |  |
| XV-1P/9.8            | 9,88                                 | 190           | 230    | X 1 P 36 01 F I I A | X 1 P 36 02 F I I A |  |

P1) Max. working pressure - P3) Max. peak pressure

For heavy-duty applications, it is recommended to check the admissible torque of the shaft

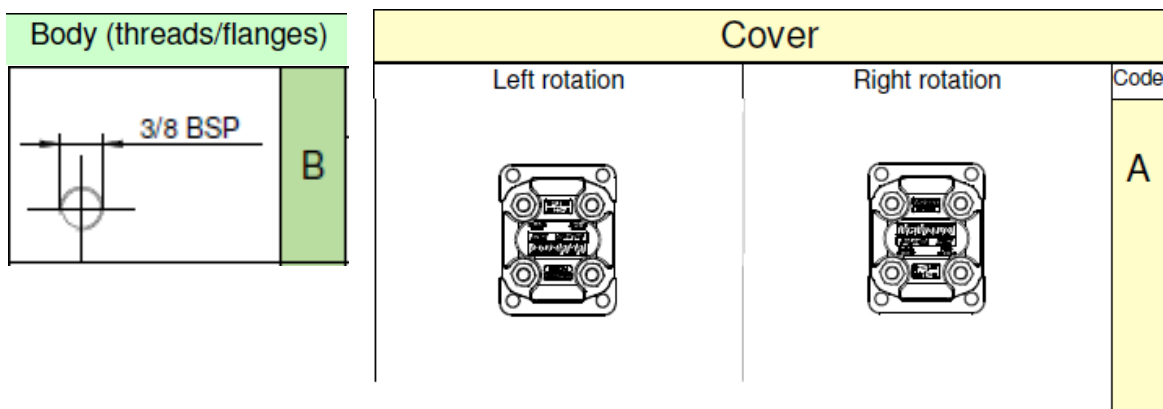

## Flow rate tables

| TYPE      | cm <sup>3</sup> /rev | rpm   |       |        |        |        |        |        |        |        |        |        |        |
|-----------|----------------------|-------|-------|--------|--------|--------|--------|--------|--------|--------|--------|--------|--------|
|           |                      | 700   | 1000  | 1500   | 2000   | 2500   | 3000   | 3500   | 4000   | 4500   | 5000   | 5500   | 6000   |
| XV 1P/0.9 | 0,91                 | 0,630 | 0,900 | 1,350  | 1,800  | 2,250  | 2,700  | 3,150  | 3,600  | 4,050  | 4,500  | 4,950  | 5,400  |
| XV 1P/1.2 | 1,17                 | 0,840 | 1,200 | 1,800  | 2,400  | 3,000  | 3,600  | 4,200  | 4,800  | 5,400  | 6,000  | 6,600  | 7,200  |
| XV 1P/1.7 | 1,56                 | 1,190 | 1,700 | 2,550  | 3,400  | 4,250  | 5,100  | 5,950  | 6,800  | 7,650  | 8,500  | 9,350  | 10,200 |
| XV 1P/2.2 | 2,08                 | 1,540 | 2,200 | 3,300  | 4,400  | 5,500  | 6,600  | 7,700  | 8,800  | 9,900  | 11,000 | 12,100 | 13,200 |
| XV 1P/2.6 | 2,6                  | 1,820 | 2,600 | 3,900  | 5,200  | 6,500  | 7,800  | 9,100  | 10,400 | 11,700 | 13,000 | 14,300 | 15,600 |
| XV 1P/3.2 | 3,12                 | 2,240 | 3,200 | 4,800  | 6,400  | 8,000  | 9,600  | 11,200 | 12,800 | 14,400 | 16,000 | 17,600 | 19,200 |
| XV 1P/3.8 | 3,64                 | 2,660 | 3,800 | 5,700  | 7,600  | 9,500  | 11,400 | 13,300 | 15,200 | 17,100 | 19,000 | 20,900 | 22,800 |
| XV 1P/4.3 | 4,16                 | 3,010 | 4,300 | 6,450  | 8,600  | 10,750 | 12,900 | 15,050 | 17,200 | 19,350 | 21,500 | 23,650 | 25,800 |
| XV 1P/4.9 | 4,94                 | 3,430 | 4,900 | 7,350  | 9,800  | 12,250 | 14,700 | 17,150 | 19,600 | 22,050 | 24,500 | 26,950 | 29,400 |
| XV 1P/5.9 | 5,85                 | 4,130 | 5,900 | 8,850  | 11,800 | 14,750 | 17,700 | 20,650 | 23,600 | 26,550 | 29,500 |        |        |
| XV 1P/6.5 | 6,5                  | 4,550 | 6,500 | 9,750  | 13,000 | 16,250 | 19,500 | 22,750 | 26,000 | 29,250 | 32,500 |        |        |
| XV 1P/7.8 | 7,54                 | 5,460 | 7,800 | 11,700 | 15,600 | 19,500 | 23,400 | 27,300 | 31,200 | 35,100 | 39,000 |        |        |
| XV 1P/9.8 | 9,88                 | 6,860 | 9,800 | 14,700 | 19,600 | 24,500 | 29,400 | 34,300 | 39,200 |        |        |        |        |

## XV-1P CHARACTERISTIC FLOW RATE CURVES

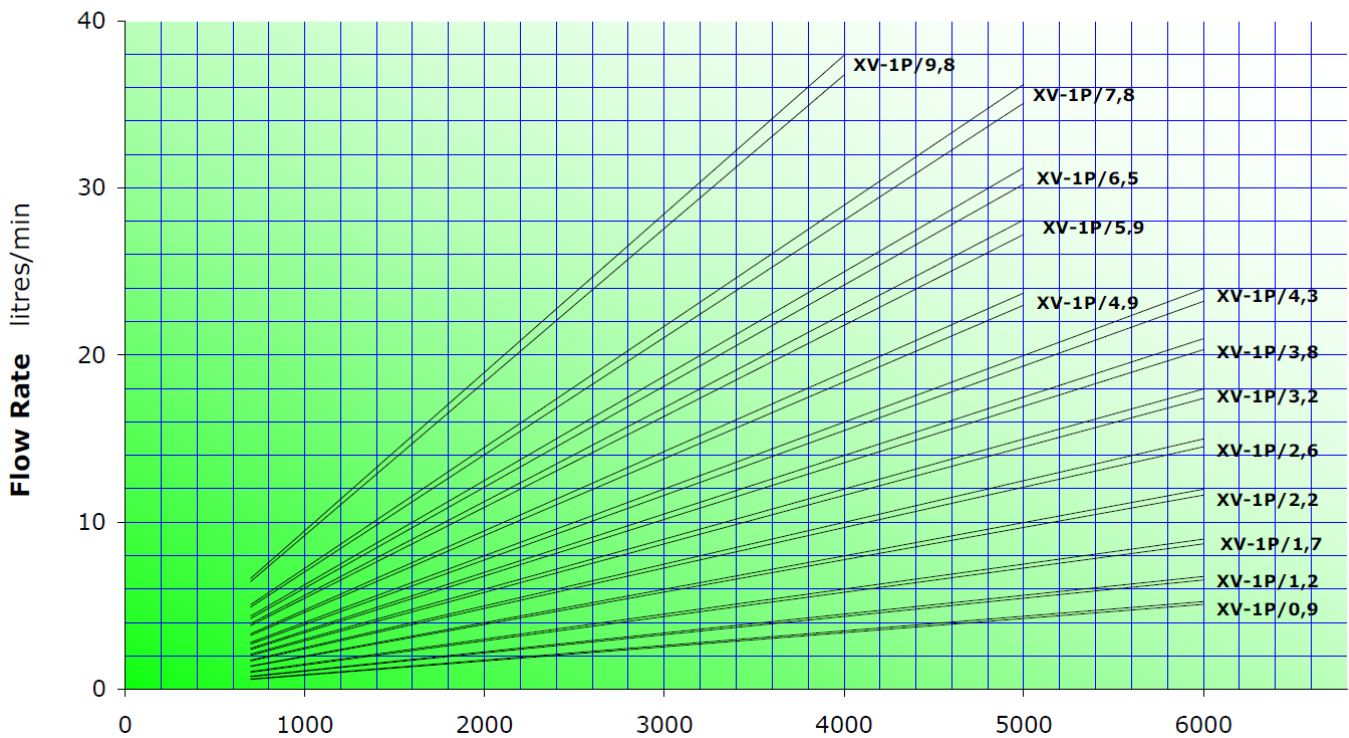

| FORMULA FOR EVALUATING SHAFT  | SHAFT [IDENTIFIER] - CODE - DESCRIPTION                                 | T.2 [Nm] |
|---|---|----------|
| $T.2 \leq \frac{v_i \times \Delta p}{20 \times \pi \times \eta m}$ <p><b>T.2</b> = max. torque allowed by shaft [ Nm]</p> | [A] - CI001 - Parallel ø12 - M10x1 - key thk. 3                         | 25,8     |
|   | [B] - CI002 - Parallel ø12.7 - key thk. 3.2 (SAE)                       | 32,8     |
|   | [C] - CF001 - Milled shank ø10 - thk.5 ("BH" Standard German)           | 13,8     |
|   | [D] - CF002 - Milled shank ø10 - thk.5                                  | 13,8     |
|   | [E] - CF003 - Milled shank ø11 - thk.6.63 (SAE)                         | 25,8     |
|   | [F] - CO001 - Tapered 1:8 - ø10 - M7x1 - key thk.2.4                    | 43       |
|   | [G] - CO002 - Tapered 1:8 - ø14 - M10x1 - key thk.3                     | 119,8    |
|   | [I] - CO004 - Tapered 1:8 - ø12.7 - 5/16" 24UNF-2A - key thk.3.2 (SAE)  | 90,4     |
|   | [J] - SCF04 - Splined ø11.7 - z=6, H=17.5, m=1.6, DIN 5482 12x9         | 22,6     |
|   | [K] - SCF05 - Splined ø12.344, z=9, H=19, SAE J498 9T 20/40DB           | 32,2     |
|   | [L] - SCF02 - Splined ø11.9, z=15, H=17.5, m=0.75                       | 42,8     |
|   | [O] - CO002+HK - Tapered 1:8 - ø14 - M10x1, HK 14-12, key thk.3         | 119,8    |
|   | [P] - CI001+HK - Parallel ø12 - M10x1 with bearing HK 14-12 - key thk.3 | 25,8     |
|   | [Q] - SCF01 - Splined ø11.9, z=15, H=9, m=0.75                          | 42,8     |
|   | [R] - SCF03 - Splined ø11.9, z=15, H=9, m=0.75                          | 42,8     |

**NOTES:**

For assemblies with a coupling, you should choose one as balanced as possible in order to reduce the vibrations and dynamic stresses to which the pump shaft may be subject.

**Always make sure that the torque applied is less than or equal to the admissible torque of the shaft.**

Do not apply a direct axial or radial load on the pump shaft; if necessary, use suitable supports.

Always use well-filtered oils containing no water or other emulsifying substance.

Never run the pump with oil and air solutions.

For pumps with outlets on the flange, it is recommended not to exceed a flow rate of



**General technical data**

|  |  |
|--|--|
| Type of fluid to be used                 | Mineral-based hydraulic oil HLP HV (D IN 51524)                |
| Minimum operating viscosity              | 10 mm <sup>2</sup> /s  |
| Maximum operating viscosity              | 100 mm <sup>2</sup> /s   |
| Maximum admissible viscosity at start-up | 1500 mm <sup>2</sup> /s  |
| Recommended viscosity                    | 20 mm <sup>2</sup> /s - 100 mm <sup>2</sup> /s                 |
| Ambient temperature                      | -20 °C - 60 °C   |
| Fluid operating temperature              | -15 °C - 80 °C   |
| Recommended fluid operating temperature  | 30 °C - 50 °C  |
| For temperatures above 120 °C            | Request FKM seals ( Viton)                                     |
| Max. inlet fluid suction pressure (IN)   | 0.02-0.08 bars   |
| Max. inlet fluid pressure (IN)           | 0.3 - 0.5 bars (for higher pressures consult the manufacturer) |
| Inlet fluid filtering (IN)               | 30 - 60 Microns  |
| Outlet fluid filtering (OUT)             | 10 - 25 Microns  |
| Max. inlet fluid speed (IN)              | 0.5 - 1.5 m/s  |
| Max. outlet fluid speed (OUT)            | 3.0 - 5.5m/s   |
| Use of water-glycol (HF-C)               | max n. of revolutions 1100 rpm; max pressure 170 bars          |

**XV1-P** with Flange  $\varnothing 25.4$  (ref. XP- 101)

When changing the direction of rotation of the XV-1P pump, it is not necessary to change the flange, as the same one is used.

When disassembling and reassembling the pump, take special care to ensure that seals and back-up rings do not come out of place and that no foreign bodies, such as shavings or dirt in general, get inside the pump.

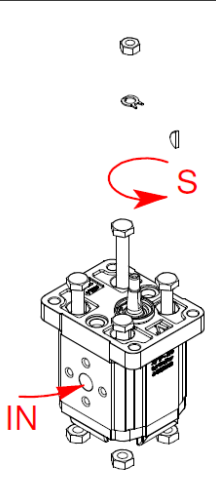
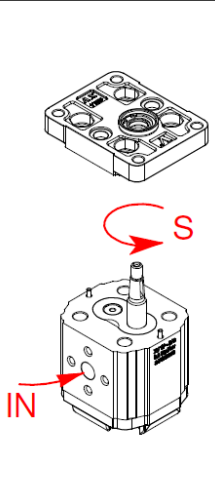
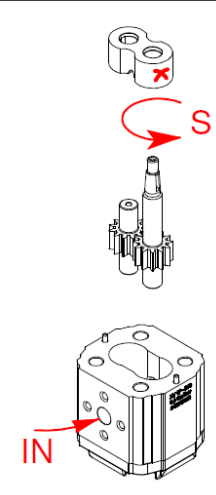
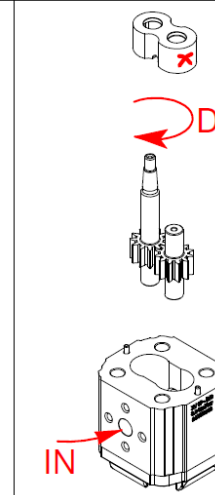
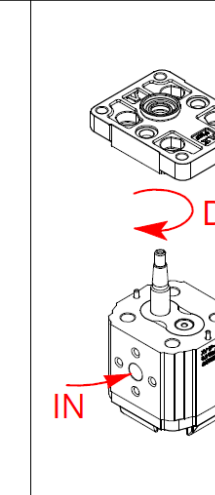
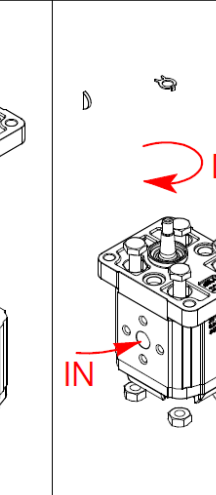
| <i>Flange <math>\varnothing 25,4</math> (ref. XP- 101)</i>                                     |  |  |   |  |   |
|--|--|--|---|--|---|
|               |  |            |    |                  |   |
| Remove the key, nut and washer from the shaft. Loosen and remove the fastening screws.         | Take off the flange.   | Take out the gears and upper bush.<br><br>Warning!!<br>The bush <b>must never</b> be turned. | Invert the positions of the driven and driving shafts.<br>Warning!<br>The body and cover must not be turned. Use the marking on the body as your reference. | Fit the previously removed flange back in place taking care to clean the body-base contact surfaces. | Replace the screws and tighten the nuts with a torque of 24.5 Nm to 29.4 Nm.<br>Check that the shaft turns on completing the operation. |
| Note: with this rotation change system, the <b>inlets</b> and <b>outlets</b> remain unchanged. |  |  |   |  |   |



### Useful calculation formulas

| SYMBOL, UNIT OF MEASUREMENT, DESCRIPTION |                       |   |
|--|-----------------------|---|
| qv                                       | l/min                 | Flow rate   |
| vi                                       | cm <sup>3</sup> /rev. | Displacement (volume of oil displaced per complete revolution of the shaft)                                 |
| n  | rpm                   | Shaft rotation speed  |
| p1                                       | bar                   | inlet pressure  |
| p2                                       | bar                   | outlet pressure   |
| Δp                                       | bar                   | Δp=p2 - p1 difference between outlet (OUT) and inlet (IN) pressure  |
| Ph                                       | kW                    | Hydraulic power delivered   |
| Pm                                       | kW                    | Mechanical power absorbed   |
| T  | Nm                    | Torque absorbed by shaft  |
| ηv                                       | -                     | 0.91 – 0.96 volumetric efficiency<br>(volumetric ratio between operation under load and loadless operation) |
| ηm                                       | -                     | 0.85 – 0.90 mechanical efficiency   |
| ηt                                       | -                     | ηt = ηv x ηm total efficiency   |

| Basic Formulas  | Derived Formulas  |  |
|---|---|--|
| $qv = \frac{vi \times n}{1000} \times \eta v$                   | $vi = \frac{qv \times 1000}{n \times \eta v}$                   | $n = \frac{qv \times 1000}{vi \times \eta v}$                |
| $T = \frac{vi \times \Delta p}{20 \times \pi \times \eta m}$    | $vi = \frac{T \times 20 \times \pi \times \eta m}{\Delta p}$    | $\Delta p = \frac{T \times 20 \times \pi \times \eta m}{vi}$ |
| $Ph = \frac{qv \times \Delta p}{600}$                           | $qv = \frac{Ph \times 600}{\Delta p}$                           | $\Delta p = \frac{Ph \times 600}{qv}$                        |
| $Pm = \frac{vi \times \Delta p \times n}{600000 \times \eta m}$ | $vi = \frac{Pm \times 600000 \times \eta m}{\Delta p \times n}$ | $\Delta p = \frac{600000 \times \eta m}{vi \times n}$        |

### Constructive features

| PART                      | MATERIAL   | MECHANICAL FEATURES   |
|---------------------------|--|---|
| <b>PUMP BODY</b>          | Extruded alloy Series 7000, heat treated and anodised  | Rp = 345 N/mm <sup>2</sup> (Yield strength)<br>Rm = 382 N/mm <sup>2</sup> (Breaking strength)         |
| <b>FLANGE AND COVER</b>   | Die-cast aluminium alloy with excellent mechanical features, heat treated and anodised   | Rp = 310÷350 N/mm <sup>2</sup> (Yield strength)<br>Rm = 350÷400 N/mm <sup>2</sup> (Breaking strength) |
| <b>GEAR BUSH BEARINGS</b> | Special heat-treated tin alloy with excellent mechanical features and high anti-friction capacity.<br>Self-lubricating bushes DU | Rp = 350 N/mm <sup>2</sup> (Yield strength)<br>Rm = 390 N/mm <sup>2</sup> (Breaking strength)         |
| <b>GEARS</b>              | Steel UNI 7846   | Rs = 980 N/mm <sup>2</sup> (Yield strength)<br>Rm = 1270÷1570 N/mm <sup>2</sup> (Breaking strength)   |
| <b>SEALS</b>              | A 727 Standard Acrylonitrile<br>F 975 Viton FKM  | 70 Shore, thermal resistance 120 °C<br>80 Shore, thermal resistance 200 °C                            |
| <b>BACK-UP RINGS</b>      | Virgin PTFE<br>Tecnil Q3   |   |



Symbols of Vivoil Oleodinamica Vivolo products

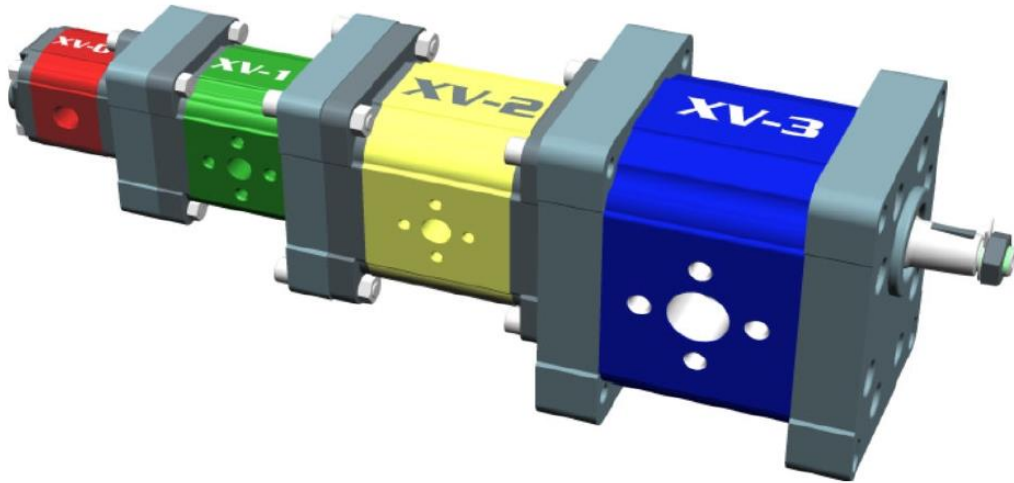

Unidirectional Pump

Left Rotation

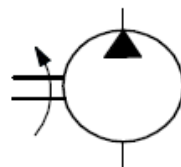

Right Rotation

