

## Additional Date/Spec Sheet

63mm Utility Pressure Gauge

Dimension Drawing:

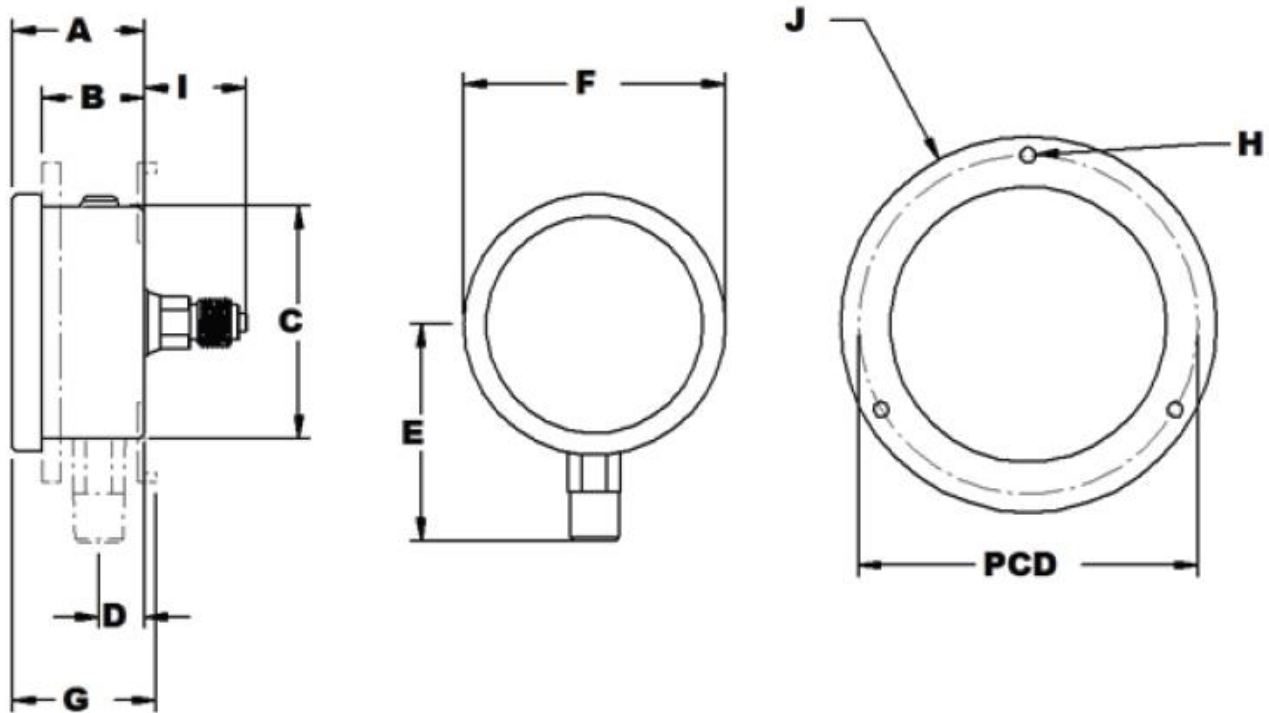

Dimensions		A	B	C	D	E	F	G	H	I	J	PCD
63 mm	Metric	35,00	28,00	62,00	10,00	60,00	69,00	38,00	3,50	27,00	85,50	75,00
2,5"	Imperial	1,38	1,10	2,44	0,39	2,36	2,72	1,50	0,14	1,06	3,37	2,95

### **Additional Information:**

A utility gauge is a mechanical device usually used for measuring the pressure of gases or liquids. It consists of a semicircular or coiled, flexible metal tube attached to a connector block. These gauges are made from brass, stainless steel and others. It is suitable for use with any liquid or gas that does not attack the copper alloys. It can be available in various dial sizes.

This gauge is commonly used for pumps, compressors, pneumatic systems and others. Moreover, utility gauges are widely used all over the world in industrial environments because of its affordable price.

## Materials

<b>Housing</b>	304SS (316SS on request)
<b>Bezel</b>	304SS (316SS on request)
<b>Window</b>	Polycarbonate or safety laminated glass
<b>Wetted Parts</b>	Brass or 316L SS (block & tube)
<b>Pointer</b>	Aluminium (black)
<b>Seals</b>	Nitrile
<b>Dial</b>	Aluminium/white background and black numerals (customized designs on request)
<b>Fill Plug</b>	2-part Body material (TPV) Plunger pin material (ABS)

## Configuration

A B C D E F U V

## Nominal Sizes

42mm(1.65") 52mm(2")  
63mm(2.5") 80mm(3") 100mm(4")

## Dampening

Glycerine filled  
Silicon filled

## Accuracy

1.6% FSD

## Nett Mass

42mm: 120g filled  
52mm: 140g filled  
63mm: 240g filled  
80mm: 400g filled  
100mm: 530g filled

## Temperature

Operating -25 DC to 60 DC  
Medium -25 DC to 85 DC  
Storage -40 DC to 85 DC

## Ingress (Weather Protection)

IP67

## Accreditation

SABS1062

## Thread Sizes

1/8 - 1/4 BSP/NPT (for other sizes and types, please contact the factory)

## Pressure Range

**Brass internals:** vacuum - 0 - 60MPa. Over Pressure Limit, 25% FSD for brief periods

**Stainless Steel internals:** vacuum - 0 - 100MPa. Over Pressure Limit, 25% FSD for brief periods

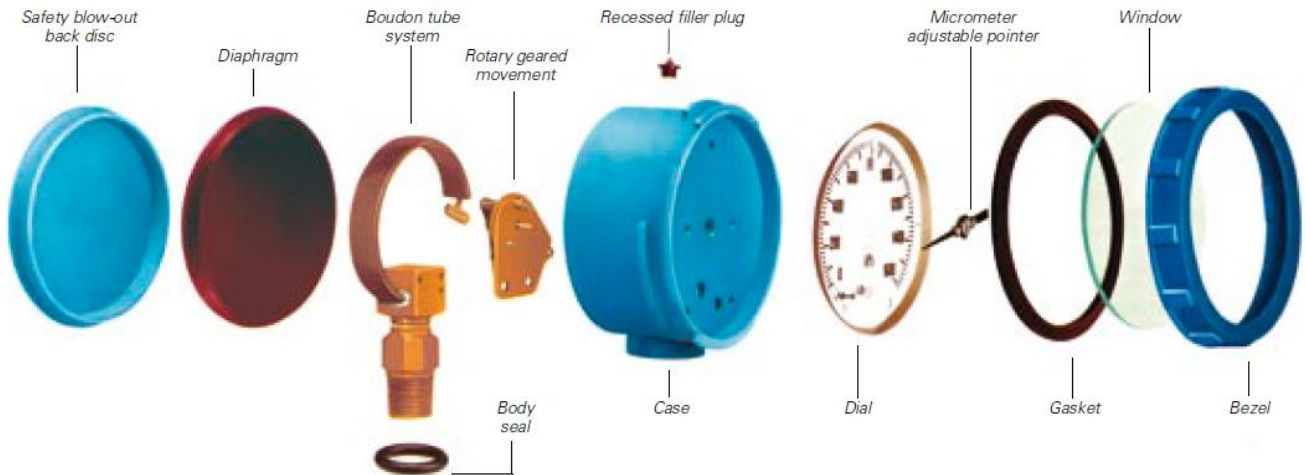

Many factors should be evaluated including temperature, vibration, process conditions, pulsation and corrosion, but by carefully considering the 7 key factors outlined below, the chances of correct selection will increase significantly.

#### Process Medium

The process medium to which the gauge will be exposed is especially important when using a thin walled Bourdon tube because, if the wrong materials are selected, corrosion may occur which could lead to catastrophic failure. Materials which display the essential combination of properties (good spring memory, easy to form, easy to join, reasonably priced) are phosphor bronze, 316 stainless steel and Monel.

Where these materials can't satisfy the application, a diaphragm seal (gauge isolator) can be added to prevent the process media from contacting the Bourdon tube. This protects the gauge from corrosion attack, and also prevents viscous or dirty media from clogging the small bore Bourdon tube. The only limitation in using a diaphragm seal is that it typically degrades the accuracy of the pressure gauge by an additional 0,5 % of the full scale deviation.

#### Pressure Gauge Range

It is important to select a pressure range which accommodates all anticipated pressure swings, and which prevents excessive needle movement. It is recommended to confine normal operating pressure to 25 % - 75 % of scale. With fluctuating pressures (e.g. pulsation caused by a pump or compressor), the maximum operating pressure should be lower (50 % of the full range).

Gauges in severe service should be liquid filled and throttled to reduce Bourdon tube stresses. To minimise sensing element stress and to extend the life of the gauge use internal throttle screws, pulsation dampeners, pressure snubbers, gauge savers or diaphragm seals.

#### The Environment

Temperature changes affect the elastic modulus of the Bourdon tube to indicate higher pressure than actual as temperature increases, (lower as temperature decreases), except if made with expensive constant modulus materials.

In a liquid filled gauge with an uncompensating case, a temperature increase of as little as 10° C results in internal case pressure build up which causes a downscale pointer shift. An upscale pointer shift can result from a temperature drop of 10° C or more. This potential error most often occurs in pressure ranges of 600 kPa or less. In gauges with true case compensation, temperature error from internal case pressure build-up is negligible.

Where ambient conditions are corrosive or contain a large number of particles, specify hermetically sealed and / or liquid filled pressure gauges to prevent foreign elements from entering the case.

Vibration can cause wear to the gears of the rotary movement and can make it difficult to accurately read pressure off an oscillating pointer. Filling a gauge with dampening fluid, such as glycerine, helps prevent these problems.

#### Accuracy

Accuracy is the conformity of a pressure gauge reading to an accepted standard (e.g. deadweight tester). Inaccuracy is the difference (error) between the true value and the indication, expressed as a percent of the span. It includes the combined errors of method, observer, apparatus and environment. Total accuracy error includes hysteresis and repeatability errors. Accuracy is not a percentage of the gauge reading - for mechanical pressure gauges, accuracy is a percentage of the full range, full scale or span of the gauge. Accurate to within the stated accuracy at 20 DC. Add or deduct 0,3 % for every 10 DC above or below the stated accuracy

#### Guidelines are:

Test Gauges (0,25 % up to 25 MPa, above 25 MPa up to 100 MPa. 0,3 %);  
Critical Processes (0,50 %); General Industry Processes (1,0 %);  
Less Critical Commercial Uses (2,0 %).

#### Dial Size

Sizes range from 40 mm to 250 mm diameters, with the 63 mm, 100 mm and 150 mm being the most popular. The dial size is generally determined by the readability requirements (larger for remote reading and smaller where the gauge is close to the operator). More accurate pressure gauges generally have larger dials as more dial graduations are needed to read the higher degree of accuracy.

#### Connections

Factors to consider include gauge pressures, size and weight, space limitations, leak integrity and past experience. 150 mm and 100 mm process gauges usually have 1/2" NPT/BSP connections, especially when direct stem mounted and liquid filled. Smaller dial sizes generally have 1/4" or 1/8" connections.

#### Mountings

Pressure gauges may be:

- Direct stem mount bottom connection;
- Remote wall - surface mount bottom connection;
- Panel surface mount back connection;
- Panel hole U clamp (yoke) flush mount back connection;
- Panel hole front flange flush mount back connection.