

Dimensional Drawings:

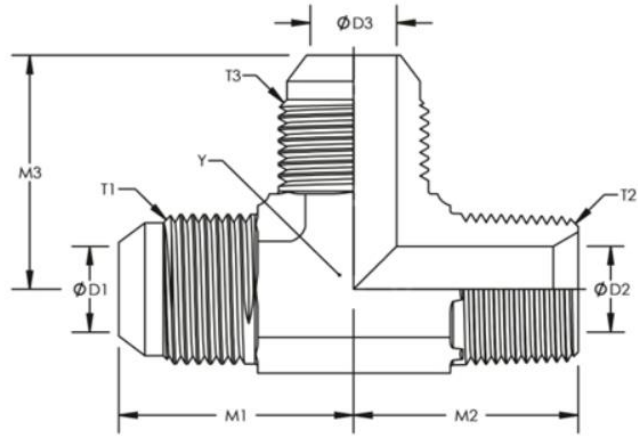

Product ID	Y HEX	T1	M1	D1	T2	M2	D2	T3	M3	D3
SS-2605-03-02-03	0.438	3/8-24	0.83	0.125	1/8-27	0.72	0.188	3/8-24	0.83	0.12
SS-2605-04-02-04	0.438	7/16-20	0.89	0.172	1/8-27	0.78	0.188	7/16-20	0.89	0.17
SS-2605-04-04-04	0.563	7/16-20	1.05	0.172	1/4-18	1.09	0.281	7/16-20	1.05	0.17
SS-2605-05-02-05	0.563	1/2-20	0.95	0.234	1/8-27	0.78	0.188	1/2-20	0.95	0.23
SS-2605-06-02-06	0.563	9/16-18	1.06	0.297	1/8-27	0.9	0.188	9/16-18	1.06	0.29
SS-2605-06-04-04	0.563	9/16-18	1.06	0.297	1/4-18	1.09	0.281	7/16-20	1.05	0.17
SS-2605-06-04-06	0.563	9/16-18	1.06	0.297	1/4-18	1.09	0.281	9/16-18	1.06	0.29
SS-2605-06-06-06	0.75	9/16-18	1.14	0.297	3/8-18	1.22	0.406	9/16-18	1.14	0.29
SS-2605-06-08-06	0.875	9/16-18	1.22	0.297	1/2-14	1.47	0.531	9/16-18	1.22	0.29
SS-2605-08-04-08	0.75	3/4-16	1.25	0.391	1/4-18	1.22	0.281	3/4-16	1.25	0.39
SS-2605-08-06-08	0.75	3/4-16	1.25	0.391	3/8-18	1.22	0.406	3/4-16	1.25	0.39
SS-2605-08-08-08	0.875	3/4-16	1.33	0.391	1/2-14	1.47	0.531	3/4-16	1.33	0.39
SS-2605-10-08-10	0.875	7/8-14	1.45	0.484	1/2-14	1.47	0.531	7/8-14	1.45	0.48
SS-2605-12-08-12	1.063	1-1/16-12	1.66	0.609	1/2-14	1.59	0.531	1-1/16-12	1.66	0.60
SS-2605-12-12-08	1.063	1-1/16-12	1.66	0.609	3/4-14	1.59	0.719	3/4-16	1.42	0.39
SS-2605-12-12-12	1.063	1-1/16-12	1.66	0.609	3/4-14	1.59	0.719	1-1/16-12	1.66	0.60
SS-2605-14-12-14	1.313	1-3/16-12	1.8	0.719	3/4-14	1.69	0.719	1-3/16-12	1.8	0.71
SS-2605-16-16-16	1.313	1-5/16-12	1.81	0.844	1-11-1/2	1.97	0.938	1-5/16-12	1.81	0.84
SS-2605-20-20-20	1.625	1-5/8-12	2.06	1.078	1-7-11-1/2	2.38	1.25	1-5/8-12	2.06	1.07
SS-2605-24-24-24	1.875	1-7/8-12	2.33	1.313	1-7-11-1/2	2.64	1.5	1-7/8-12	2.33	1.31

SAE J514 Pressure Ratings					
Nom. SAE Dash Size	Nom. Tube O.D. Inches	37 Degree Flare Straight Thread	Nom. Pipe Size	SAE St. Threads Union & Bulkhead (PSI)	Fittings With Pipe Threads (PSI)
2	1/8	5/16"-24	1/8"	5000	5000
3	3/16	3/8"-24	1/8"	5000	5000
4	1/4	7/16"-20	1/8"	5000	5000
5	5/16	1/2"-20	1/8"	5000	5000
6	3/8	9/16"-18	1/4"	5000	5000
8	1/2	3/4"-16	3/8"	4500	4000
10	5/8	7/8"-14	1/2"	3500	3000
12	3/4	1 1/16"-12	3/4"	3500	3000
14	7/8	1 3/16"-12	3/4"	3000	2500
16	1	1 5/16"-12	1"	3000	2000
20	1 1/4	1 5/8"-12	1 1/4"	2500	1150
24	1 1/2	1 7/8"-12	1 1/2"	2000	1000
32	2	2 1/2"-12	2"	1500	1000

NOTE: Since many factors influence the pressure at which a system will or will not perform satisfactory, values shown in this table should not be construed as guaranteed minimum.

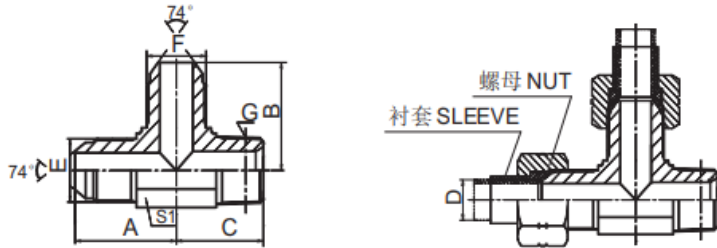

AJJN

JIC 外螺纹 / JIC 外螺纹 / 布锥管外螺纹
JIC MALE / JIC MALE / NPT MALE

代号 PART NO.	螺纹 THREAD			尺寸 DIMENSIONS					
	E	F	G	A	B	C	S1		
AJJN-04	7/16"X20	7/16"X20	Z1/4"X18	26.6	26.6	25.5	14		
AJJN-04-04-02	7/16"X20	7/16"X20	Z1/8"X27	24.5	24.5	21	11		
AJJN-05-05-02	1/2"X20	1/2"X20	Z1/8"X27	26.6	26.6	23.5	14		
AJJN-05-05-04	1/2"X20	1/2"X20	Z1/4"X18	26.6	26.6	25.5	14		
AJJN-06	9/16"X18	9/16"X18	Z3/8"X18	30	30	31	19		
AJJN-06-04-06	9/16"X18	7/16"X20	Z3/8"X18	30	29.5	31	19		
AJJN-06-06-04	9/16"X18	9/16"X18	Z1/4"X18	26.9	26.9	25.5	14		
AJJN-06-06-08	9/16"X18	9/16"X18	Z1/2"X14	32	32	36.7	22		
AJJN-08	3/4"X16	3/4"X16	Z1/2"X14	34.8	34.8	36.7	22		
AJJN-08-08-06	3/4"X16	3/4"X16	Z3/8"X18	32	32	31	19		
AJJN-08-08-12	3/4"X16	3/4"X16	Z3/4"X14	37.9	37.9	44	27		
AJJN-10-10-08	7/8"X14	7/8"X14	Z1/2"X14	37.8	37.8	36.7	22		
AJJN-10-10-12	7/8"X14	7/8"X14	Z3/4"X14	41	41	44	27		
AJJN-12-12-08	1.1/16"X12	1.1/16"X12	Z1/2"X14	44.2	44.2	37.9	27		
AJJN-12	1.1/16"X12	1.1/16"X12	Z3/4"X14	44.2	44.2	44	27		
AJJN-14-14-12	1.3/16"X12	1.3/16"X12	Z3/4"X14	47.5	47.5	45	30		
AJJN-16-16-12	1.5/16"X12	1.5/16"X12	Z3/4"X14	49	49	46.5	33		
AJJN-16	1.5/16"X12	1.5/16"X12	Z1"X11.5	49	49	50	33		