

B2-9

90° SWIVEL CONNECTOR m BSP X f BSP

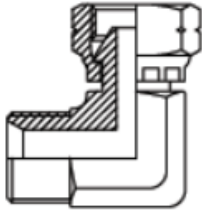

Part No.	Thread	
	E	F
B2029	G1/8"X28	G1/8"X28
B2049	G1/4"X19	G1/4"X19
B2069	G3/8"X19	G3/8"X19
B2089	G1/2"X14	G1/2"X14
B2129	G3/4"X14	G3/4"X14
B2169	G1"X11	G1"X11
B2209	G1 1/4"X11	G1 1/4"X11
B2249	G1 1/2"X11	G1 1/2"X11
B2329	G2"X11	G2"X11

INCH SIZE	DASH SIZE	OD	ID MALE THREAD (MM)	PITCH (MM)	THREADS PER INCH	PITCH DIAMETER	THREAD HEIGHT (MM)	TAP DRILL DIAMETER (MM)
1/4"	04	13.157	11.445	1.337	19	12.301	0.856	11.6
3/8"	06	16.662	14.95	1.337	19	15.806	0.856	15
1/2"	08	20.955	18.631	1.814	14	19.793	1.162	19
5/8"	10	22.911	20.587	1.814	14	21.749	1.162	20.75
3/4"	12	26.441	24.117	1.814	14	25.279	1.162	24.5
7/8"	14	30.201	27.877	1.814	14	29.039	1.162	28
1"	16	33.249	30.291	2.309	11	31.77	1.479	30.5

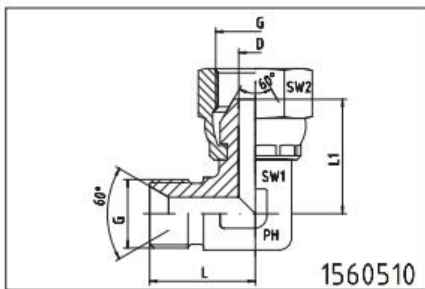

Gewinde Thread G	ca. Maße approx. dimensions					Bestellzeichen Order-Code
	L	L1	D	SW1	SW2	
1/8"-28	20,0	18,0	4,0	12	14	1560510-02
1/4"-19	24,5	23,5	6,0	14	19	1560510-04
3/8"-19	25,5	25,5	8,0	17	22	1560510-06
1/2"-14	29,5	29,5	11,0	19	27	1560510-08
3/4"-14	37,0	37,0	16,0	27	32	1560510-12
1"-11	43,0	43,0	22,0	36	41	1560510-16
1 1/4"-11	51,0	51,0	28,0	41	50	1560510-20
1 1/2"-11	59,0	50,0	33,5	50	55	1560510-24
2"-11						1560510-32

2B9 90°;BSP MALE 60°;SEAT/ BSP FEMALE 60°;CONE industrial pipe fittings .

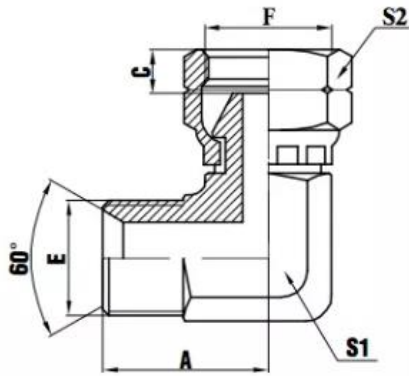

2B9

90° 英管外螺纹60° 内锥/
 英管内螺纹60° 外锥
 90° BSP MALE 60° SEAT/
 BSP FEMALE 60° CONE

代号 PART NO.	螺纹 THREADS		尺寸 DIMENSIONS				
	E	F	A	C	S1	S2	
2B9-02	G1/8"X28	G1/8"X28	23	5.5	11	14	
2B9-04	G1/4"X19	G1/4"X19	29	5.5	14	19	
2B9-04-06	G1/4"X19	G3/8"X19	30	6.5	17	22	
2B9-06	G3/8"X19	G3/8"X19	30	6.5	17	22	
2B9-06-04	G3/8"X19	G1/4"X19	30	5.5	17	19	
2B9-08	G1/2"X14	G1/2"X14	37	8	22	27	
2B9-08-06	G1/2"X14	G3/8"X19	37	6.5	22	22	
2B9-10	G5/8"X14	G5/8"X14	37	10.5	22	30	
2B9-10-08	G5/8"X14	G1/2"X14	37	8	22	27	
2B9-12	G3/4"X14	G3/4"X14	41	11.5	27	32	
2B9-16	G1"X11	G1"X11	49	11.5	33	41	