

Call: 021 511 0590

Email: service1@fluidco.co.za

40 Industry Road, Paarden Eiland



FLUIDCO

HYDRAULIC SYSTEMS



PTO Catalogue

Pumps

Valves

Tanks

Accessories

Make it Happen!!

www.fluidco.co.za

Fluidco - P.T.O Pumps & Components Catalogue - Page Index

DESCRIPTION	PG NR
Piston Pumps 3&4 Bolt	1
Bent Axis Piston Pumps	2
Double Bent Axis Piston Pumps	3
Gear Pumps 3&4 Bolt	4
Front Gear / Tandem Pump	5
Double Vane Pump	5
30 Series Gear Pump Spares	6
40 Series Gear Pump Spares	6
Bent Axis Pump Suction Flange	6
Vane Pump Flange	6
Gaskets	6
Billets	7
P.T.O Accessories & Valves	7
Pneumatic Tip Valves	7
Pneumatic Cab Control Kits	7
Cab Switch Brackets	8
Pneumatic Cab Switches	8
P.T.O Boxes - Pneumatic Actuated PTO's	8
Side Mount Tanks	9
Behind Cab Mount Tanks	9
P.T.O Tail Lift Mini Power Packs	10

Straight Piston Pumps - 4 Bolt

	Straight Piston Pumps are Bi-Rotational, 4 Bolt, 8 Spline Shaft, Max Continuous speed(min-1)1200, Min Intermittent speed(min-1)400
PTO-P16-S4	16cc, 350Bar Single Pump
PTO-P20-S4	20cc, 350Bar, Single Pump
PTO-P32-S4	32cc, 350Bar Single Pump
PTO-P50-S4	50cc, 350Bar Single Pump
PTO-P60-S4	60cc, 350Bar Single Pump
PTO-P80-S4	80cc, 280Bar Single Pump
PTO-P106-S4	106cc, 280Bar Single Pump
PTO-P50-S4-LP	50cc Low Pressure 250Bar Single Pump



Straight Piston Pumps - 3 Bolt

	Straight Piston Pumps are Bi-Rotational, 3 Bolt, 6 Spline, 350Bar Max Continuous speed(min-1)1200, Min Intermittent speed(min-1)400
PTO-P20-S3	20cc Single Pump
PTO-P34-S3	34cc Single Pump
PTO-P46-S3	46cc Single Pump
PTO-P60-S3	60cc Single Pump

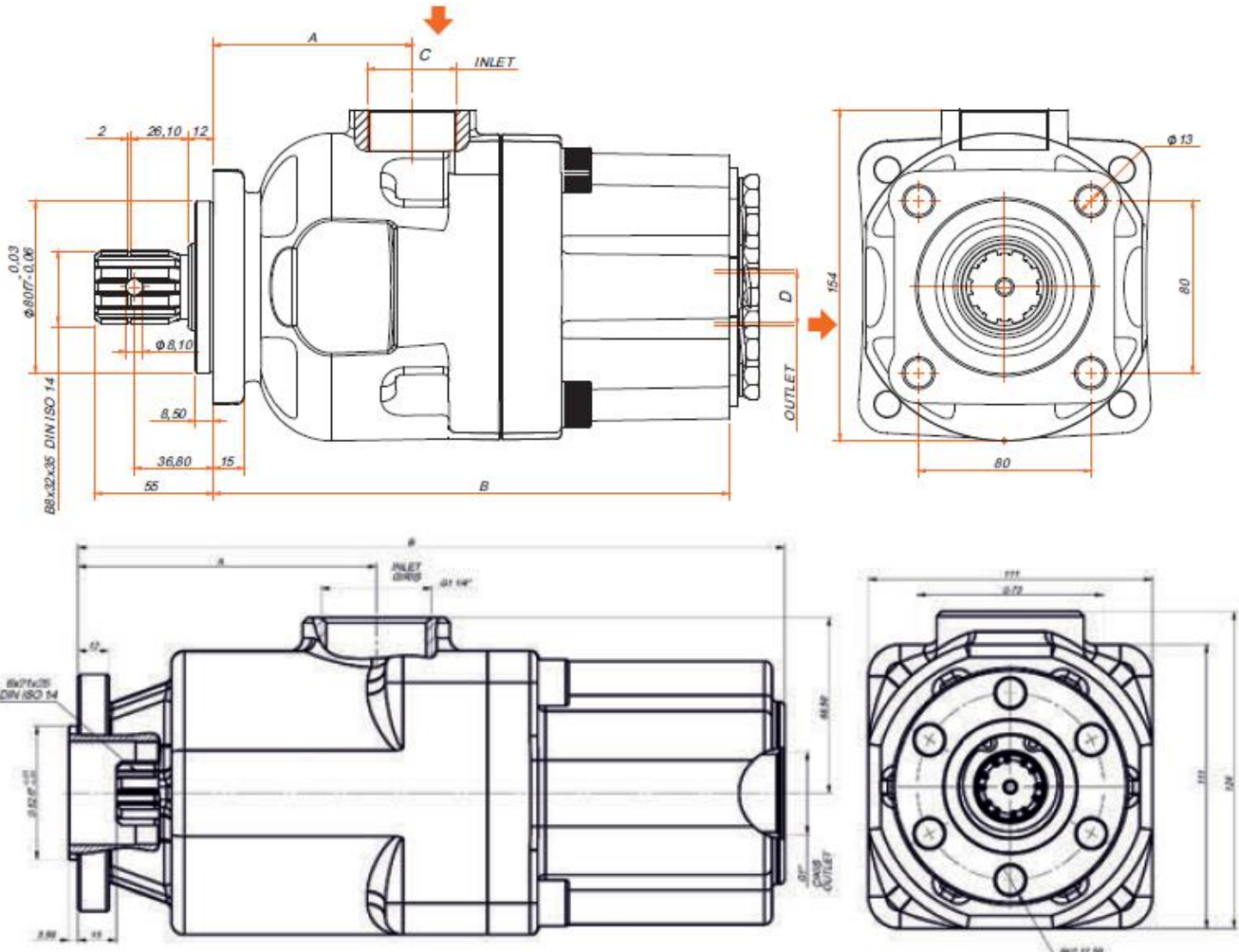

Bent Axis Piston Pumps - 4 Bolt

	Standard CW rotation, but can be changed to ACW
	350Bar & Peak at 400Bar
PTO-P12-B4	12cc Single Pump
PTO-P18-B4	18cc Single Pump
PTO-P25-B4	25cc Single Pump
PTO-P40-B4	40cc Single Pump
PTO-P55-B4	55cc Single Pump
PTO-P63-B4	63cc Single Pump
PTO-P80-B4	80cc Single Pump
PTO-P108-B4	108cc Single Pump
PTO-P130-B4	130cc Single Pump



How to change the direction of rotation of the pump

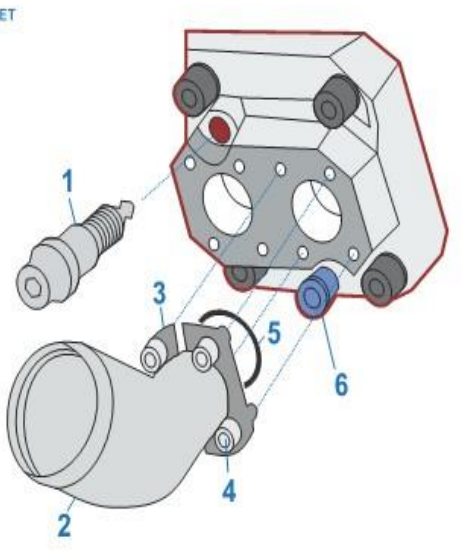
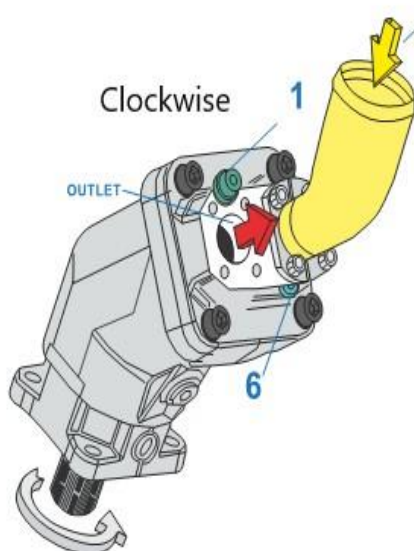
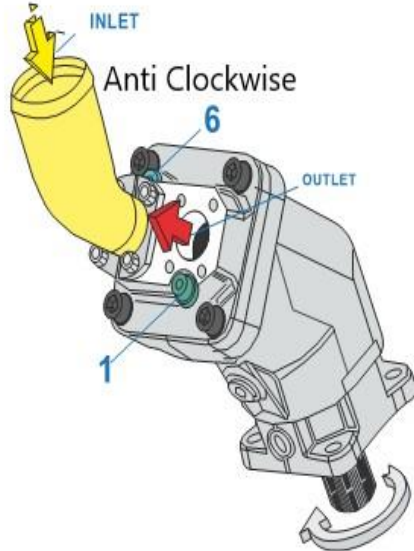

To check in which direction the pump should rotate on your installation:

- Check the direction of rotation of the PTO;
- If the PTO turns clockwise, the pump must rotate counter-clockwise, and vice versa.

To change the direction of rotation of your 2PBA pump:

- Remove the inlet fitting (2) and the 2 parts of the split flange (3).
- Remove the rotation setting screw (1).
- Remove the plug (6).

- Put the rotation setting screw (1) where the plug (6) was, and the plug (6) where the rotation setting screw (1) was.
- Put seal (5) on the inlet fitting, then the inlet fitting on the side where the plug (6) is, and fix with the split flange. Tighten with the screws (4).

Important note:

Do not rotate pump shaft at all until the rotation setting screw (1) is in place. The rotation setting screw is always on the output (pressure) side.

Most sizes can be ordered / converted to a 3 Bolt, request on enquiry to confirm.

Double Bent Axis Piston Pumps - 4 Bolt

PTO-P70-70-B4	Dual Flow Best Axis Piston Pump
	70cc + 70CC, Din Mounting Flange
	Min 50Bar, Mid 350Bar, Max 450Bar
	8x32x36 Shaft Type, Rear Cover
	1 Inlet & 2 Outlets, 1000-5500RPM
	Single Flow Cast Iron Body
	Standard CW rotation, can be changed to AWC on request



Double Bent Axis Piston Pump

Installation dimensions

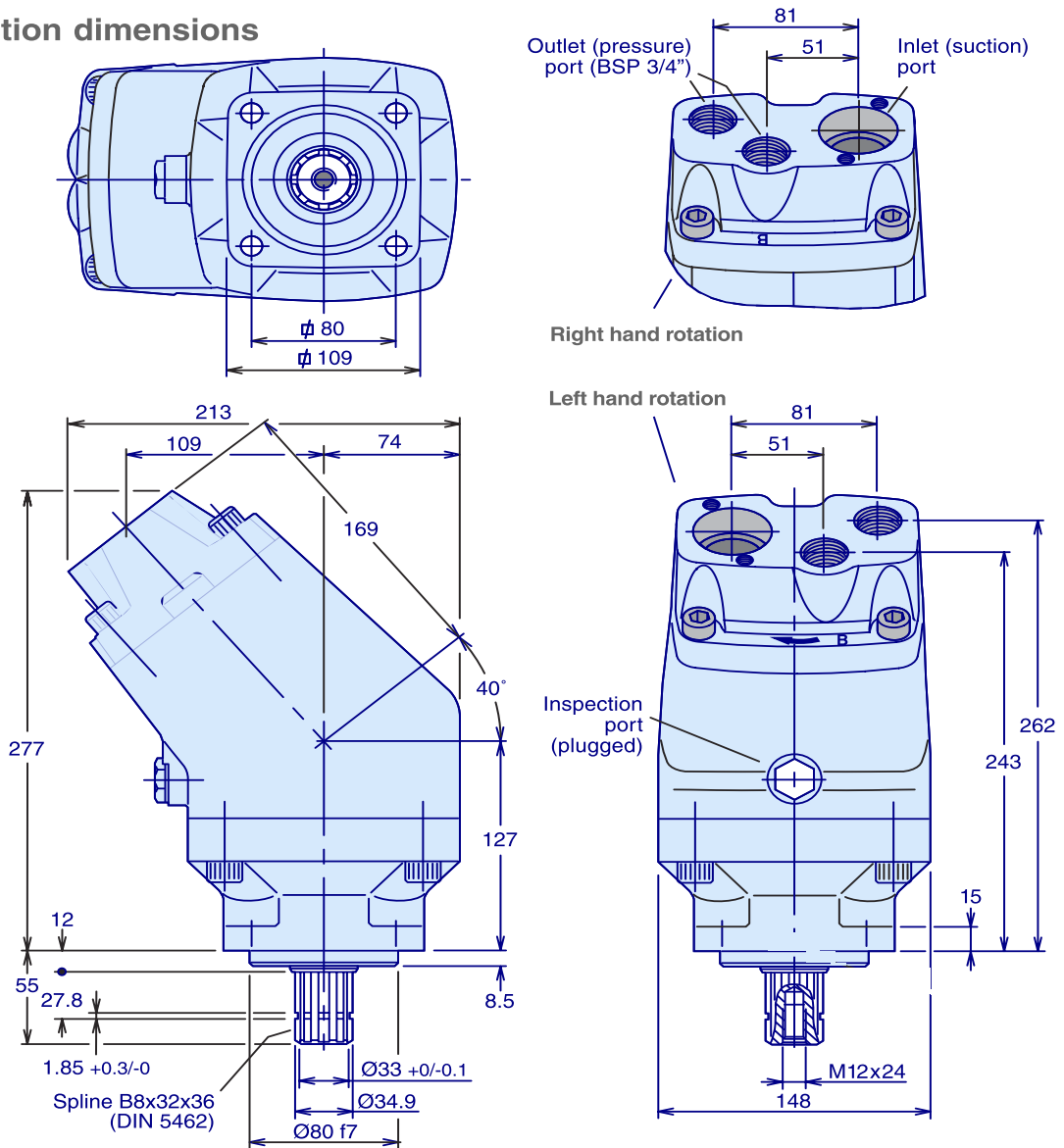

Gear Pumps - 4 Bolt

	4 Bolt PTO Truck Gear Pumps, 8 Spline Shaft - Uses Only 70% WP!
	Rotation required (CW / ACW) should be given on order
PTO-GP-017-3H	17cc, 260Bar, G12-08
PTO-GP-027-3H	27cc, 260Bar, G12-08
PTO-GP-034-3H	34cc, 260Bar, G16-12
PTO-GP-043-3H	43cc, 260Bar, G16-12
PTO-GP-051-3H	51cc, 240Bar, G16-12
PTO-GP-061-3H	61cc, 220Bar, G16-12
PTO-GP-082-3H	82cc, 180Bar, G16-12



Gear Pumps - 3 Bolt

	3 Bolt PTO Truck Gear Pumps, 6 Spline Shaft - Uses Only 70% WP!
	Rotation required (CW / ACW) should be given on order
PTO-GP-017-3H	17cc, 260Bar, G12-08
PTO-GP-027-3H	27cc, 260Bar, G12-08
PTO-GP-034-3H	34cc, 260Bar, G12-08
PTO-GP-043-3H	43cc, 260Bar, G16-12
PTO-GP-051-3H	51cc, 240Bar, G16-12
PTO-GP-061-3H	61cc, 220Bar, G16-12
PTO-GP-082-3H	82cc, 180Bar, G16-12



Drive Shaft in Higher Position and Belly of Pump DOWN

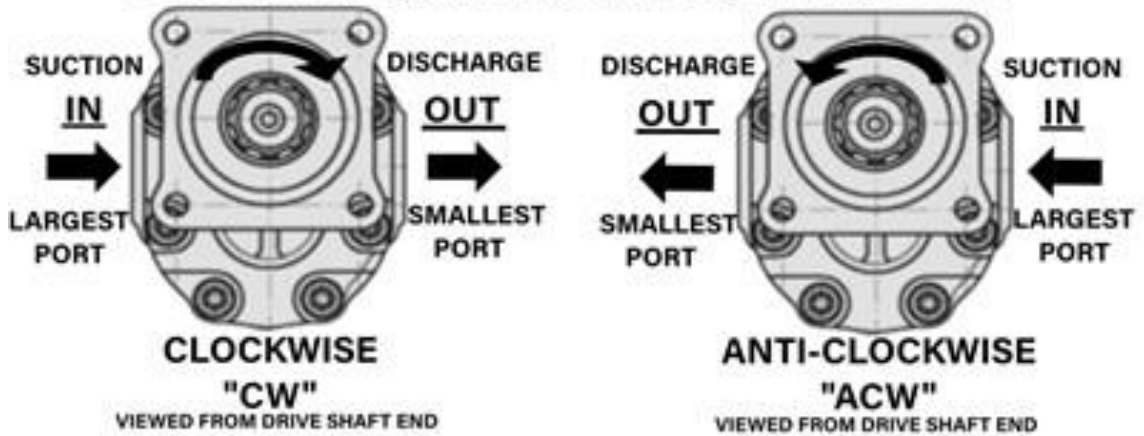

Drive Shaft in Lower Position and Belly of Pump UP

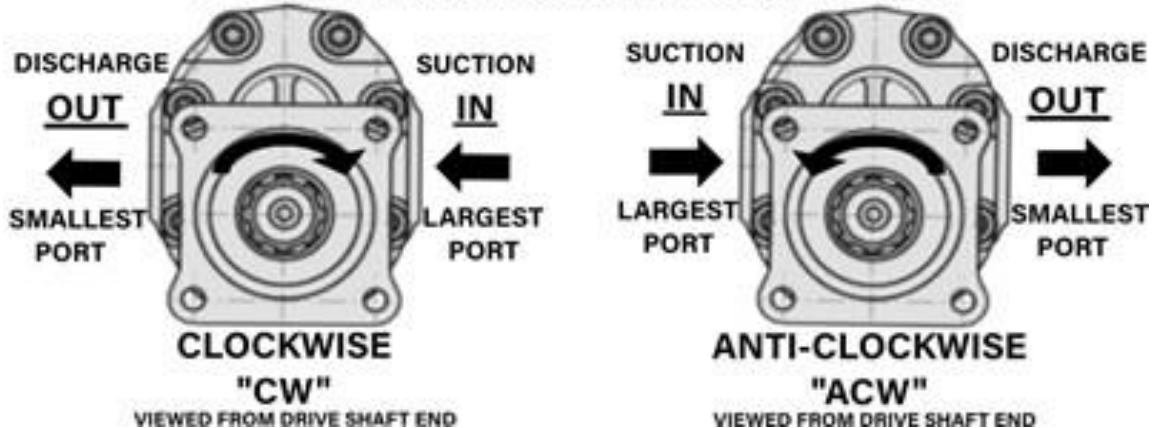

Front Gear Pumps - 4 Bolt

	The Rotation of the Front Pumps CANNOT be changed
PTO-GP-73-4R-FT	73cc, 200 Bar, CW, 8 Spline Takes a 3 Bolt Rear Pump to make a Double Gear Pump
PTO-GP-63-4L-FT	63cc, 200 Bar, ACW, 8 Spline Takes a 3 Bolt Rear Pump to make a Double Gear Pump

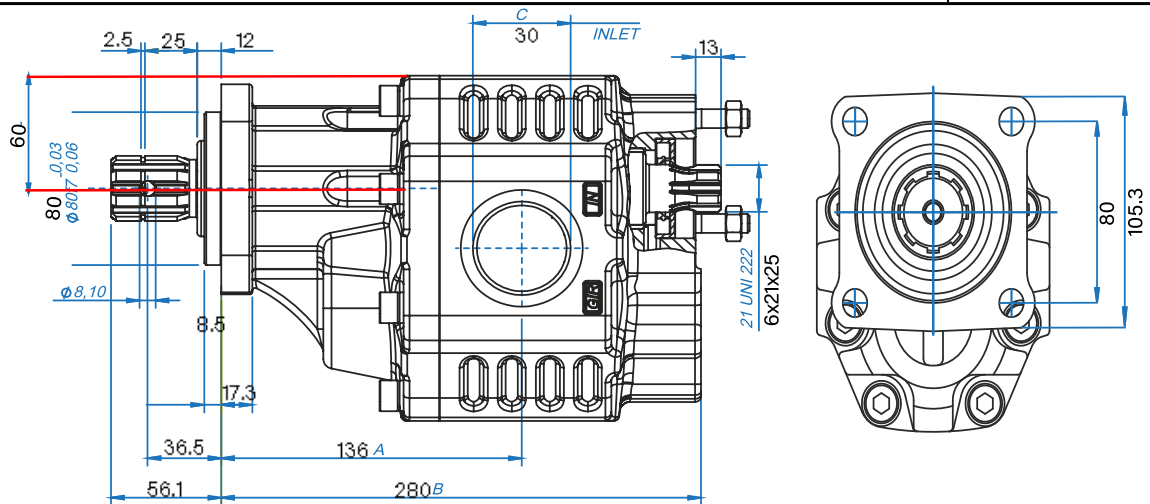

Double Vane Pump

PTO-VP-70-70-R4	70cc + 70cc, 280Bar, 8 Spline shaft, Rotation can be changed
------------------------	---





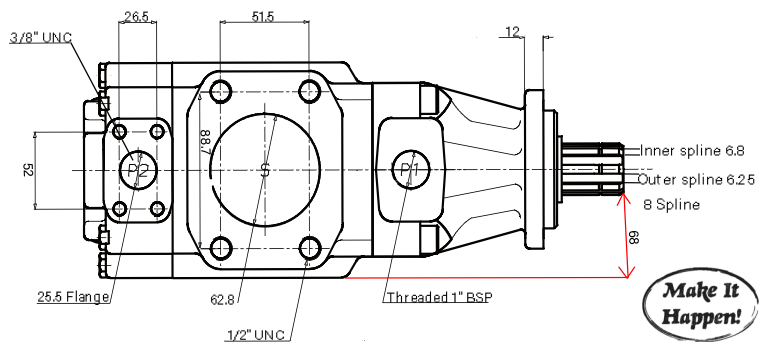
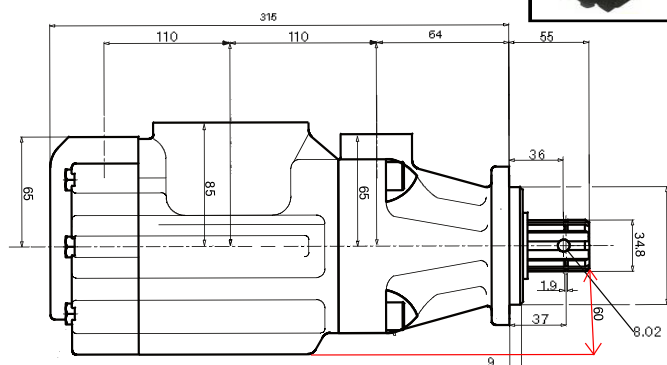
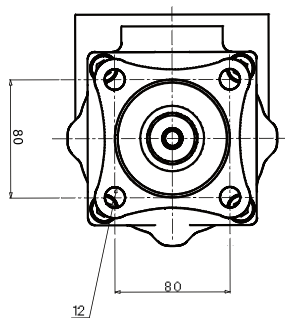

ODF Double Vane Pump
Dimensions in mm

Weight 27.2 kg





30 Series Gear Pump Spares

30 Series - Normal Small Frame - Brown - Pump Spares

	Gear Pump Front Cover	
PTO-GP-30-FC-3H	3 Hole, Size 30, for 17cc - 61cc Pumps	
	Gear Pump Front Cover	
PTO-GP-30-FC-4H	4 Hole, Size 30, for 17cc - 61cc Pumps	
PTO-GP30-OB	4 Hole - Gear Pump Outer Bearing: 6207-ZZC3	
PTO-GP30-SS	3 or 4 Hole - Gear Pump Inner Shaft Seal: SM 25x40x08/7	
	Gear Pump Wear Plate Kit - Small	
PTO-GP30-WP	For 27cc - 83cc 30 Series Pump Includes Wear Plate & Kidney Seals	
PTO-GP30-IB	4 Hole - Gear Pump Inner Bearing: 6007-ZZC3	
PTO-GP30-DS	4 Hole - Gear Pump Outer Dust Seal: SM 42x72x10	

40 Series Gear Pump Spares

40 Series - Large Frame - Blue - Gear Pump Spares

	Gear Pump Wear Plate Kit - Large	
PTO-GP40-WP	for 63cc - 73cc Pumps Includes Wear Plate & Kidney seals	
PTO-GP40-DS	4 Hole - Gear Pump Outer Dust Seal: for 63cc-73cc Pumps	



Bent Axis Piston Pump Suction Flange Fitting

PTO-FLANGE-16	JIC Male - 16 / 1" - Flange for Bent Axis Pumps	
PTO-FLANGE-20	JIC Male - 20 / 1 1/4" - Flange for Bent Axis Pumps	
PTO-FLANGE-24	JIC Male - 24 / 1 1/2" - Flange for Bent Axis Pumps	





Vane Pump Flange

PTO-VP-FLANGE-2	Special Flange, 3000psi, for Vane Pumps	
------------------------	--	---







Gaskets

PTO-GASKET-3H	Gasket for 3 Hole Mounting	
PTO-GASKET-4H	Gasket for 4 Hole Mounting	







Billets

	Female Spline Billet	
BILL-6T-1PTO	6 Tooth, K16, including 3 Hole Gasket 1 - 25,4mm X 25mm PTO Coupling	
		
BILL-8T-35FPTO	Female Spline Billet, 8 Tooth PTO Flange	
		
BILL-8T-35MPTO	Male Spline Billet, 8 Tooth PTO Flange	
		
BILL-8T-35PTO	Female Spline 8 Tooth Billet	



P.T.O Accessories / Valves

	PTO Adaptor, Pump Converter	
PTO-AD-3-4B	Converts a 3 Bolt/Hole Pump to a 4 Bolt/Hole Includes a PTO Female Billet & 4 Hole Gasket	
		
PTO-AD-4-3B	PTO Adaptor, Pump Converter Converts a 4 Bolt/Hole Pump to a 3 Bolt/Hole Includes a PTO Female Billet & 4 Hole Gasket	
		
PTO-AD-4-4T	PTO Adaptor Spaces 4 Bolt/Hole Pumps Male/Female	
		
PTO-LV-NC	Push in 2/2 Deceleration Valve 2 Port, 2 Position G12, Normally Closed	
		
PTO-LV-NO	Push in 2/2 Deceleration Valve 2 Port, 2 Position G12, Normally Open	



Pneumatic Tip Valves

	Pneumatic Tip Valve G12 - Aluminum Cap - No Hold	
PTO-DOP19-AL	280Bar, 140LPM, P=Check Valve, Cyl=1"port next to P, T=3/4" - 12 port on side, Parallel to the relief	
		
PTO-DOP19-CI	Pneumatic Tip Valve G12 - Cast Iron Cap - No Hold 280Bar, 140LPM, P=Check Valve, Cyl=1"port next to P, T=3/4" - 12 port on side, Parallel to the relief	
		
PTO-DOP19-2SP	Pneumatic Tip Valve 2 Speed ø3/4" - 12 BSP ø3/4" - 1 JIC ø1/4" - 4 BSP	
		
PTO-TIP-H-TP10	Pneumatic Tip Valve HC-TP10, with Hold 3/4" - 12 BSP, 100Lpm, 350Bar, 1/8" - 02	

Pneumatic Cab Control Kits

	1 Lever Cab Control Kit	
PTO-CCK1	Includes a Single Bracket and 3 Way Pneumatic Cab Switch Cab Switch is 5/3 & Spring Centred with G-02	
		
PTO-CCK2	2 Lever Cab Control Kit Includes a Double Bracket and 2x 3 Way Pneumatic Cab Switch Cab Switch is 5/3 & Spring Centred with G-02	





Cab Switch Brackets

PTO-CS1-BR-H	PTO Horizontal Bracket for 1 Lever Cab Switch	
PTO-CS1-BR-V	PTO Vertical Bracket for 1 Lever Cab Switch	

Pneumatic Cab Switches

	Pneumatic Air Switch	
PTO-CS-1L-01	Single / 1 Lever Cab switch Without Light, No hold, G-02 1/8" BSP, Max 10Bar	
	Pneumatic Air Switch	
PTO-CS-2L-01	Double / 2 Lever Cab switch With Light, No hold, G-02 1/8" BSP, M12x1,5, Max 10Bar	
	Pneumatic Cab Switch	
PTO-CS-1L-2POS	1 Joystick, 2 Position with Light & Hold 2 Position Joystick with 2 Lock positions for hold	
	Pneumatic Cab Switch	
PTO-CS-1L-3POS	1 Joystick, 3 Position with Light & Hold. 3 Position Joystick with 2 Lock positions for hold	
	Pneumatic Cab Control Switch	
PTO-CS-2L3-H-01	2 Lever, 3 Position with Light & Hold Min 5Bar, Max 12Bar - G02 1/8"	
	Pneumatic Cab Switch	
PTO-CS-5/3	5 Port, 3 Position 1 Lever, 3 way, Spring Centered, G02 1/8"	
	Pneumatic Cab Switch	
PTO-CS-MW701-01	1 Lever, 3 way, Spring Centered, G02 1/8" G02 Metal work, P-Blocked, A&B vented in Neural	
	Pneumatic Cab Switch	
PTO-CS-MW882-01	Push-Pull, Knockout Fail-safe, G02 1/8" 3/2 Push Button Valve with pilot knockout (Fail-Safe)	

P.T.O Boxes - Pneumatic Actuated PTO's

PTO-ZF-SQ	PTO 4 Bolt Square for ZF-type Gearbox	
PTO-ZF-OFFSET	PTO 4 Bolt Offset for ZF-type Gearbox 280Nm for 16 Speed Boxes ZF16S-130/160/190/221	
PTO-ZF16S221IT	PTO Shaft ZF-16 Speed Intarder	
PTO-FUL-BOT-3H	PTO 3 Bolt, Bottom Mount - Fuller Box	
PTO-MER55649603	Adaptor + Shaft for Merc G131/210/240/260/221	

Side Mount Tanks

	All tanks are supplied with Air Breather, Tank mounted return Filter and Oil Level Indicator
PTO-TK085SM	Truck Side Mount Tank - 65/85L
PTO-TK090SM-AL	Truck Side Mount Tank - 80/100L - Aluminum Tank
PTO-TK100SM	Truck Side Mount Tank - 100/120L
PTO-TK130SM	Truck Side Mount Tank - 130/160L
PTO-TK170SM	Truck Side Mount Tank - 160/190L
PTO-TK200SM	Truck Side Mount Tank - 180/210L
PTO-TK250SM	Truck Side Mount Tank - 220/250L

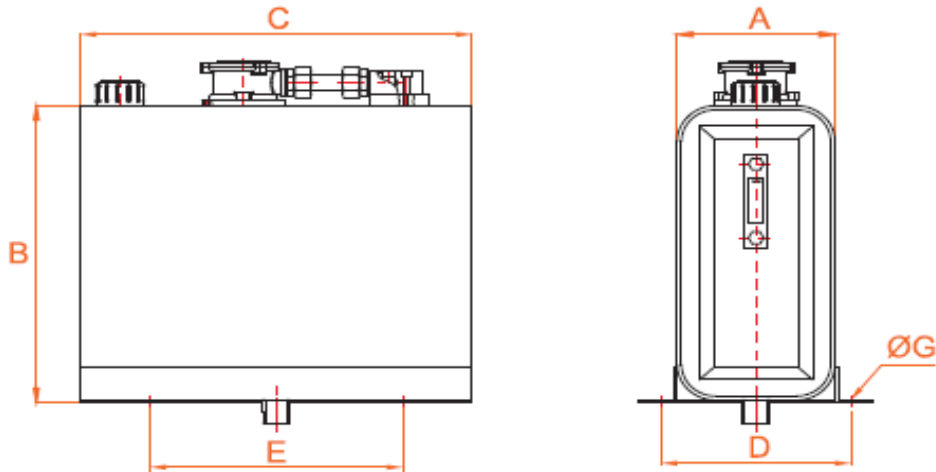

* DIMENSIONS ON REQUEST

Behind Cab Mount Tanks

	All tanks are supplied with Air Breather, Tank mounted return Filter and Oil Level Indicator
PTO-TK065BC	Truck Behind Cab Mount Tanks - 55/65L
PTO-TK095BC	Truck Behind Cab Mount Tanks - 75/95L
PTO-TK105BC	Truck Behind Cab Mount Tanks - 90/105L
PTO-TK130BC	Truck Behind Cab Mount Tanks - 100/130L
PTO-TK150BC	Truck Behind Cab Mount Tanks - 130/155L
PTO-TK170BC-AL	Truck Behind Cab Mount Tanks - 150/175L
PTO-TK170BC	Truck Behind Cab Mount Tanks - 150/175L
PTO-TK180BC	Truck Behind Cab Mount Tanks - 180/200L
PTO-TK220BC	Truck Behind Cab Mount Tanks - 190/220L
PTO-TK260BC	Truck Behind Cab Mount Tanks - 220/265L
PTO-TK280BC	Truck Behind Cab Mount Tanks - 250/285L

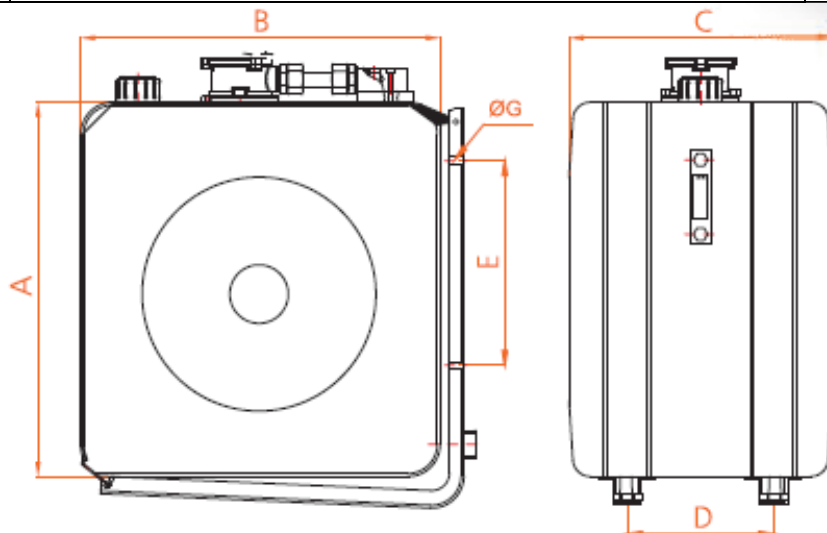

* DIMENSIONS ON REQUEST

PTO Tail Lift Mini Power Pack

PTO-PP-24V-SA	DC Electric Motor Mini Power Unit
	21cc, 2300Rpm, Non-Ventilated
	Voltage: 24V
	Power: 2.0kW
	Tank Size: 15L
	Degree of Protection - IP54



**We supply and Manufacture a range of Power Packs & Mini Power Packs.
We offer the Design & Manufacturing of Power Packs to your specific specifications.**

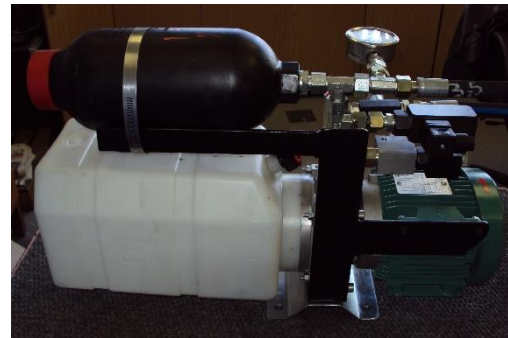

We stock a wide variety of PTO and Hydraulic components. Your one stop Hydraulic shop!

