

DN 3-4-5-6

DISTRIBUTORI MONOBLOCCO MONOBLOCK DIRECTIONAL VALVES EINBLOCKSTEUERGERÄTE

DATI TECNICI • TECHNICAL DATA • TECHNISCHE MERKMALE

Portata nominale (max) Nominal flow (max) Nominaler Durchfluß (max)	45 (55) l/min 11.9 (14.5) gpm
Pressione massima Maximum pressure Maximaler Betriebsdruck	300 (4351) bar (psi)
Contropressione massima allo scarico Maximum tank pressure Maximaler Gegendruck Tankleitung	50 (730) bar (psi)
Massima trafila interna Maximum internal leakage Maximale interne Leckage	8 cc/min (21 cSt - 100 bar)
Temperatura d'utilizzo Temperature range Betriebstemperatur	-20°C +80°C NBR seals -20°C +130°C HNBR seals
Viscosità olio Oil viscosity Ölviskosität	Da 10 cSt a 100 cSt From 10 cSt to 100 cSt Von 10 cSt nach 100 cSt
Fluido Fluid Öl	Olio a base minerale Mineral based oil Mineral Öl

FILETTATURA • THREAD • GEWINDE

CODICE MODEL BEZEICHNUNG	TIPO TYPE GEWINDE	COPPIA DI SERRAGGIO Nm TORQUE Nm ANZUGSMOMENT Nm
C	M 18 X 1,5	40
B	1/2 Gas	70
E	3/4" UNF-16	50

DIMENSIONI • SIZE • ABMESSUNGEN

N° DI SEZIONI N° OF SECTIONS ANZAHL ELEMENTE	L mm (inch)	MASSA Kg (lb) WEIGHT Kg (lb) GEWICHT Kg (lb)
DN3	151 (5.94)	7.3 (16.0)
DN4	191 (7.52)	9.4 (20.7)
DN5	231 (9.1)	11.5 (25.3)
DN6	271 (10.67)	13.6 (30.0)

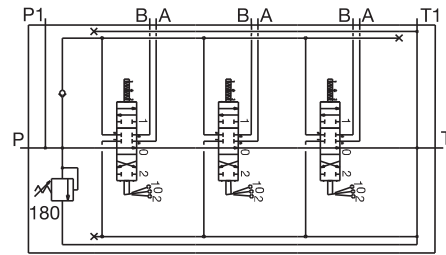

DN/3 BZ A1x3 PP1TT1

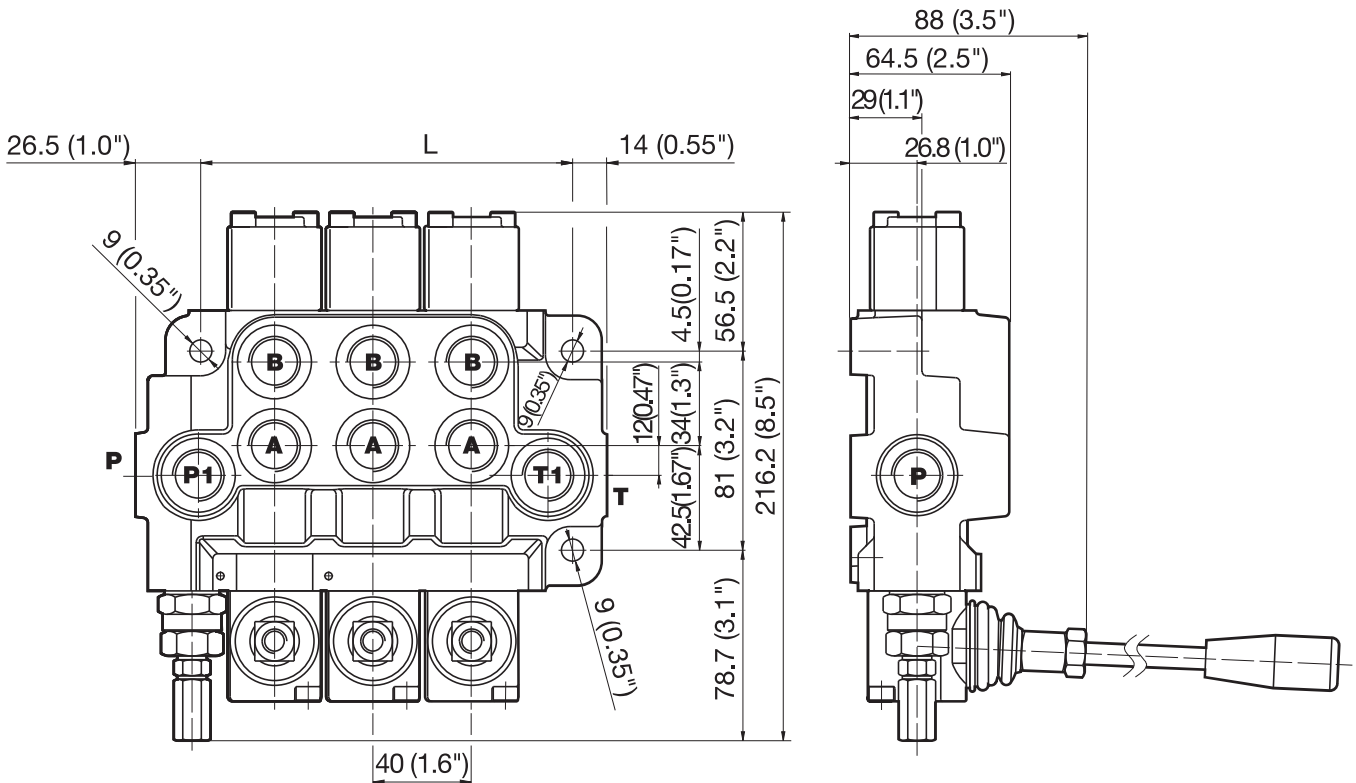
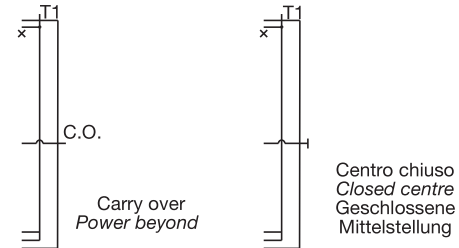



CURVE CARATTERISTICHE
FLOW CURVES
TYPISCHE KURVEN

Le curve caratteristiche in catalogo sono tipiche di prodotti di produzione testati in laboratorio e non sono necessariamente rappresentative di ogni unità.
Performance Characteristics shown in catalog are typical of production products tested in laboratory and are not necessarily representative of any other unit.
Die Werte im Katalog beziehen sich auf Standardware, die auf der Prüfbank getestet wurde und sind nicht repräsentativ für andere Einheiten.

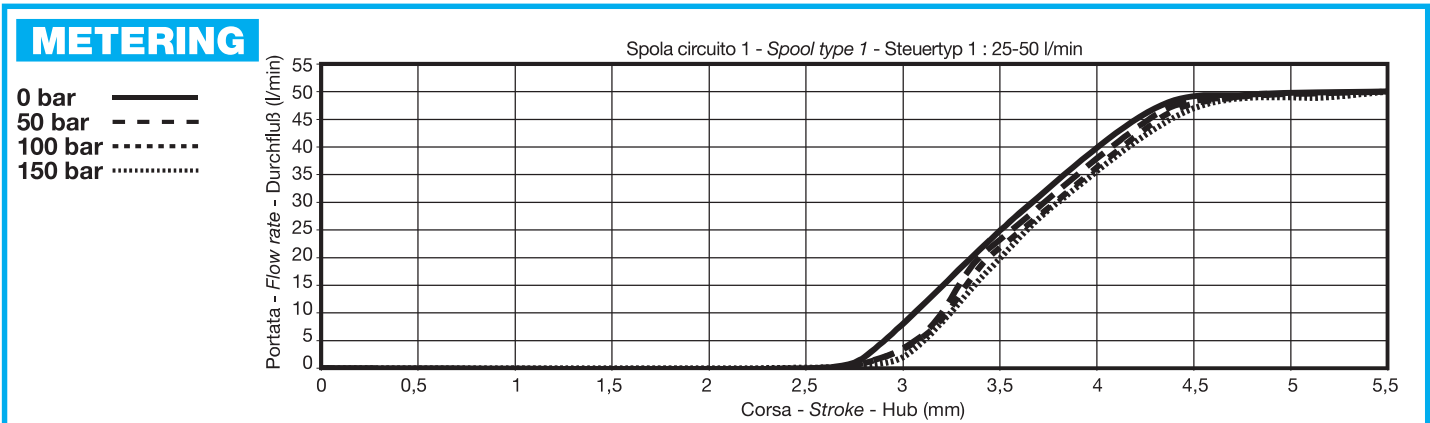
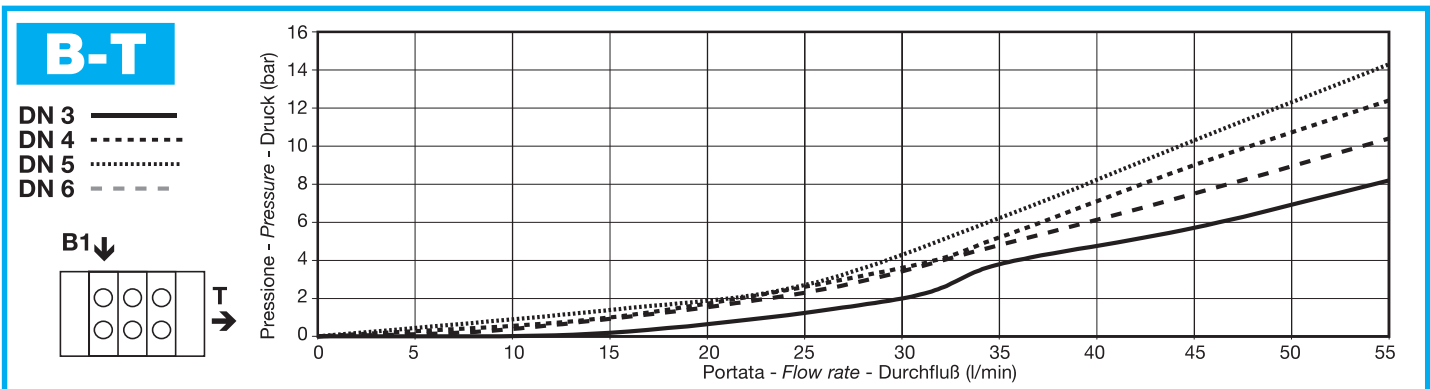
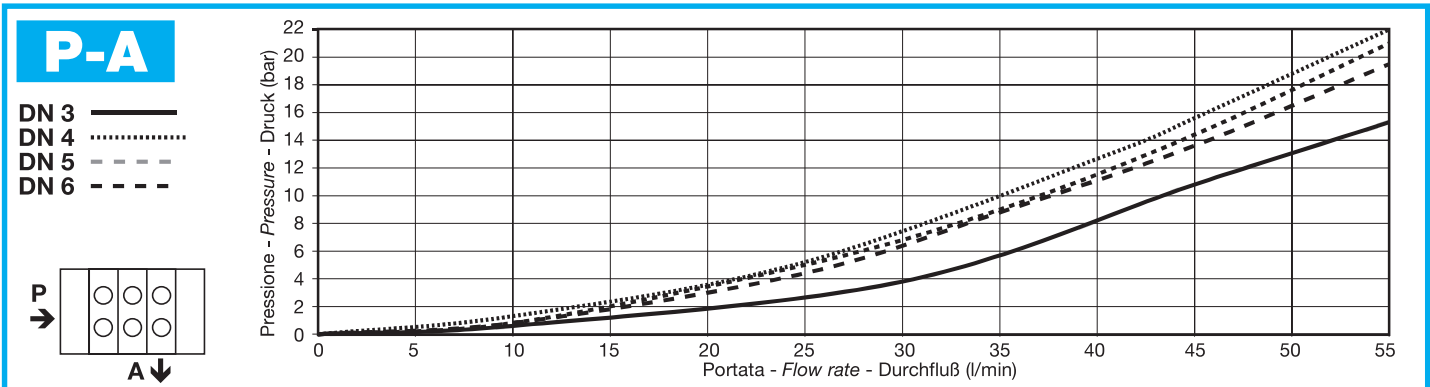
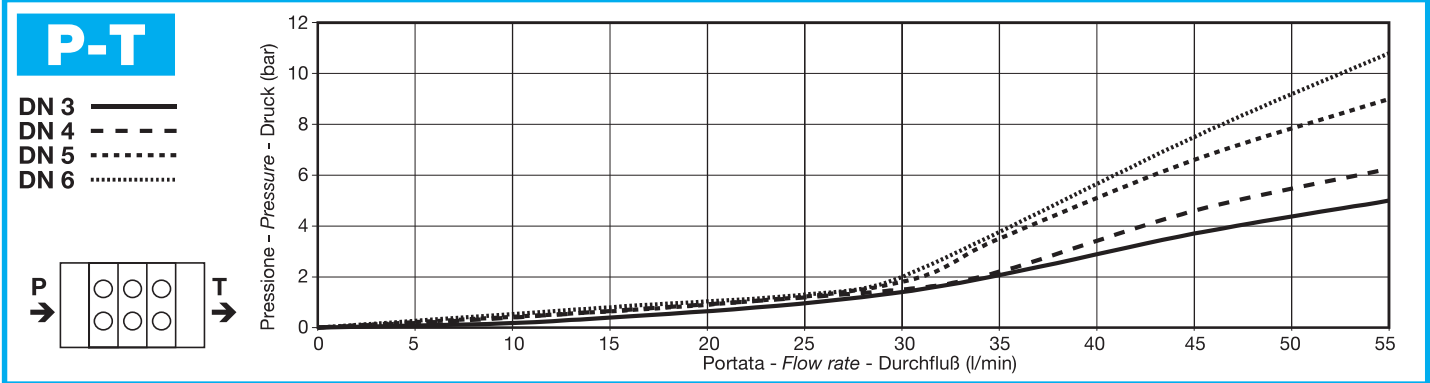

Parametri di prova / Testing parameters / Prüfparameter: 50°C - 21 cSt (spola circuito 1 - spool type 1 - steuertyp 1)

CIRCUITI E SCHEMI IDRAULICI HYDRAULIC CIRCUITS AND SCHEMES STEUERTYPEN UND HYDRAULISCHE SCHEMATA

Le configurazioni indicate sono relative a prodotti standard. Per altre configurazioni prego contattarci.
The following configurations are related to standard products. Please, contact us for other configurations.
Die abgebildeten Produkte sind typische Standardwaren. Sollten Sie für Ihre Anwendung Änderungen benötigen, wenden Sie sich bitte an uns.

POSIZIONATORE • SPOOL CONTROL • SCHIEBERSTELLUNG		CIRCUITO • SPOOL TYPE • STEUERTYP						
			POS. 3	POS. 1	POS. 0	POS. 2	POS. 4	
A		Posizione neutra in 0 Neutral position in 0 Neutralstellung in 0	1					
B		Posizione neutra in 0, detent in 1 Neutral position in 0, detent in 1 Neutralstellung in 0, rastend in 1	3					
C		Posizione neutra in 0, detent in 2 Neutral position in 0, detent in 2 Neutralstellung in 0, rastend in 2	4					
D		Detent in 0, 1, 2 Raststellung in 0, 1 und 2	5					
NT		Posizione neutra in 0, detent in 4 Neutral position in 0, detent in 4 Neutralstellung in 0, rastend in 4	70					
R		Posizione neutra in 2 Neutral position in 2 Neutralstellung in 2						
S		Posizione neutra in 1 Neutral position in 1 Neutralstellung in 1						

ACCESSORI ACCESSORIES ZUBEHÖR

Per maggiori informazioni contattateci.
For more information please contact us.
Bei weiteren Fragen nehmen Sie bitte Kontakt mit uns auf.

LATO POSIZIONATORE SPOOL CONTROL SIDE STEUERSCHIEBERSEITE

Azionamento elettroidraulico
Electrohydraulic actuator
Elektrohydraulische Steuerung

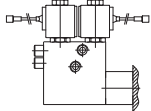

Azionamento elettropneumatico
Electropneumatic actuator
Elektropneumatische Steuerung

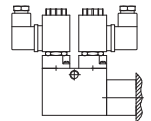

Azionamento pneumatico
Pneumatic actuator
Pneumatische Steuerung

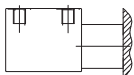

Azionamento idraulico diretto
Direct hydraulic actuator
Direkte Hydraulische Steuerung

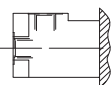

Posizionatore per doppio comando
For double control spool control
Anbausatz Doppelsteuerung

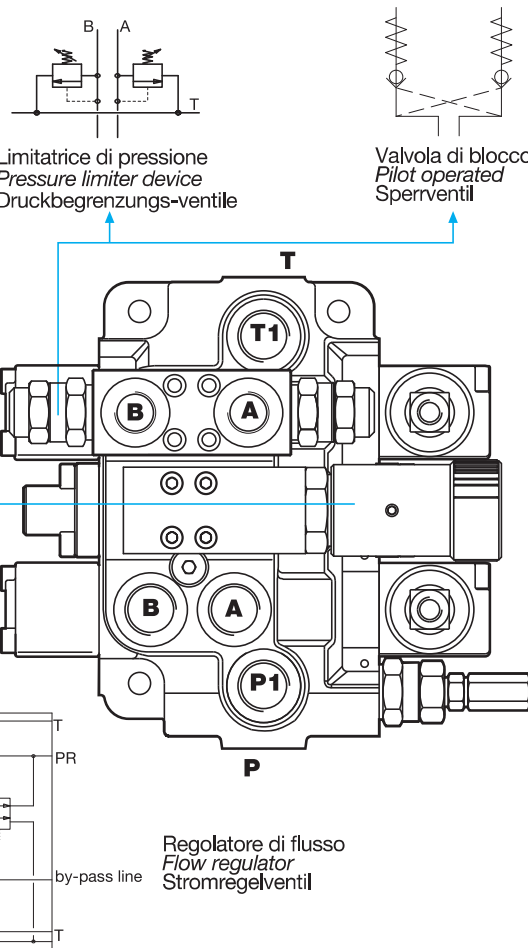
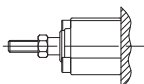

LATO AZIONAMENTO ACTUATOR SIDE HEBELSEITE

Leva intenzionale
Intentional lever
Sicherheitshebel

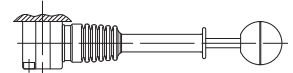

Blocco leva per cavo
Driving block for cable
Hebeleinheit für Bowdenzug

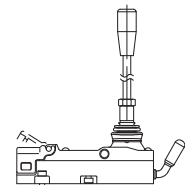

Manipolatore
Joystick
Joystick

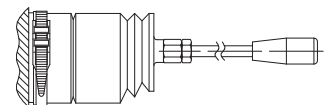

Limitatore di corsa
Stroke limiter
Hubbegrenzer

