

Dimensions

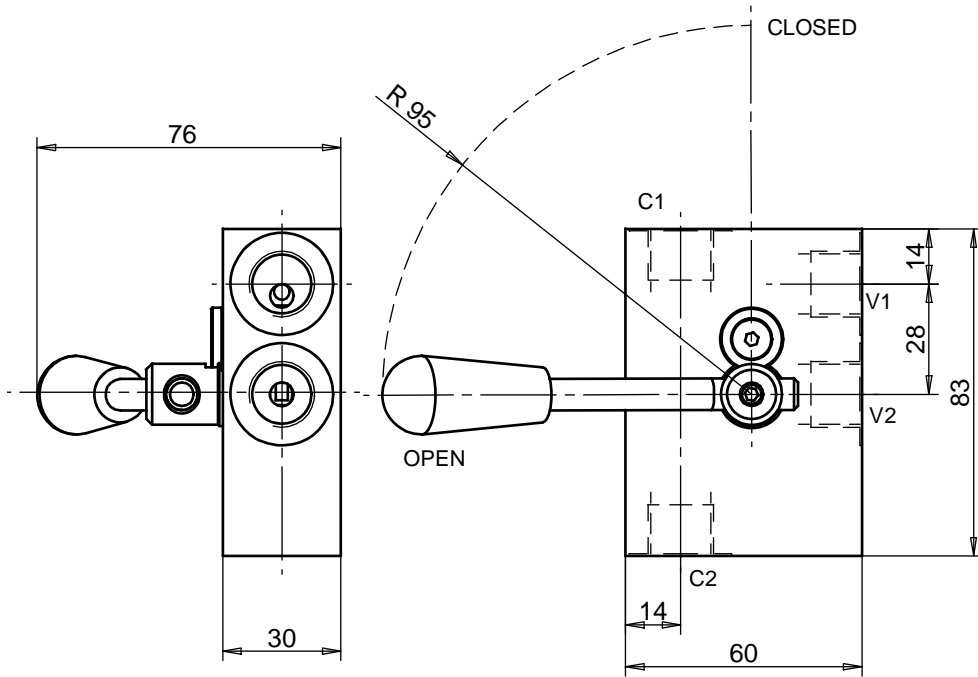

Hydraulic Symbol

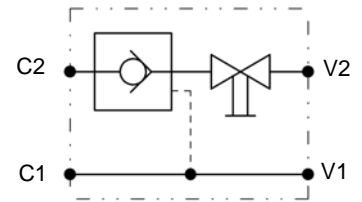

Curves

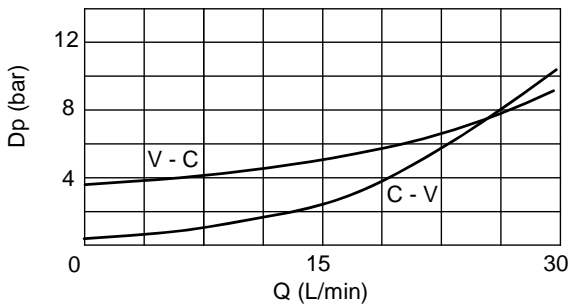

Features

Max Flow	30 lpm
Max Pressure	350 bar
Pilot Ratio	4:1
Cracking Pressure	0,5 bar
Ports	3/8 bsp

Materials: Zinc plated steel cartridge, hardened steel inner parts.
Aluminium manifold.

Ordering Code

LVSLRS 02