

Additional Information

For: Pneumatic HC-TP10 Tip Valve 3/4"

Installation Dimensions

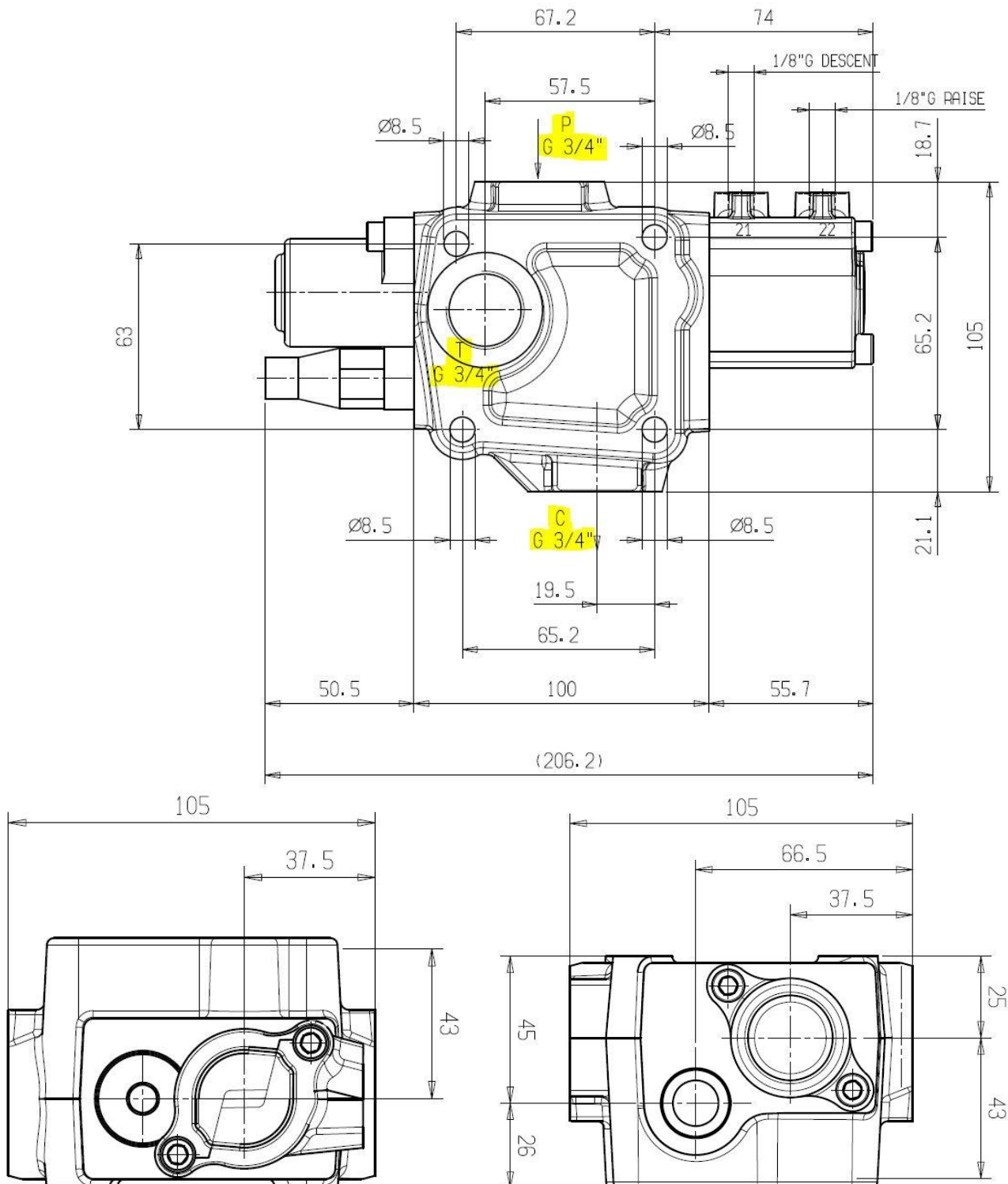

Symbol Drawing

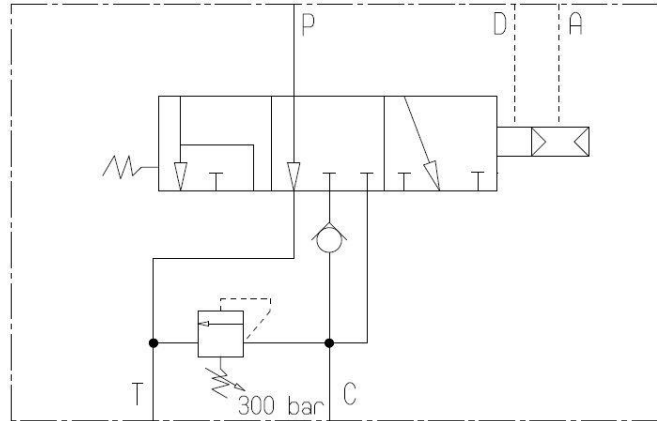

Standard Working Conditions

STANDARD WORKING CONDITION	
Max. Inlet Flow	100 l/min
Max. Input Pressure	350 bar
Max. back pr. on Tank line	20 bar
Operating temperature range	-20/+80°C
Kinematic Viscosity Range	10-300 cst
Max. Contamination level	9 (NAS 1638) - 20/18/15 (ISO 4406: 1999)
Recommended Filtration level	b10 >75 (ISO 16889 : 2008)
Pneumatic Working Pressure	6-8 bar
Ports Dimensions	
Tank Port T	3/4" BSP
Inlet Port P	3/4" BSP
Cylinder Port C	3/4" BSP